



*Conceiving, Planning and Development in scientific electronics*

**ALPHA PARTICLE COUNTING SYSTEM *CALPH***  
**USER MANUAL**

Rel. 01.01.0000  
(Hardware Code: ALFA01-9501)



---

Information provided in this manual is property of IPSES S.r.l. and must be considered and treated as confidential.

This publication can only be reproduced, transmitted, transcribed or translated into any human or computer language with the written consent of IPSES S.r.l.

Information in this documentation has been carefully checked and is believed to be accurate as of the date of publication; however, no responsibility is assumed of inaccuracies. IPSES will not be liable for any consequential or incidental damages arising from reliance on the accuracy of this documentation.

Information contained in this manual is subject to change without notice and does not represent a commitment on the part of IPSES. The design of this instrument is subject to continue development and improvement. Consequently, the equipment associated to this document may incorporate minor changes in detail from the information hereafter provided.

All brand or product names are trademarks or registered trademarks of their respective holders.

This manual in English is the original version.

Printed in Italy

Copyright © 2005-2009 IPSES S.r.l.

All rights reserved.



## GUARANTEE

IPSES warrants to the end-user in accordance with the following provisions that its branded hardware products, purchased by the end-user from IPSES company or an authorized IPSES distributor will be free from defects in materials, workmanship and design affecting normal use, for a period of one year as of the original purchase date. Products for which proper claims are made will, at IPSES's option, be repaired or replaced at IPSES's expense<sup>1</sup>.

### Exclusions

This Guarantee does not apply to defects resulting from: improper or inadequate installation, use or maintenance; actions or modifications by unauthorized third parties or the end-user; accidental or wilful damage or normal wear and tear.

### Making a claim

Claims must be made by contacting IPSES office within the guarantee period.

Please, contact:

**IPSES S. r. l. - Via Trieste, 48 - 20020 Cesate (MI) Italy**

Tel. (+39) 02/9906845 - Fax (+39) 02/700403170

<http://www.ipses.com> - e-mail [support@ipses.com](mailto:support@ipses.com)

### Limitation and Statutory Rights

IPSES makes no other warranty, guarantee or like statement other than as explicitly stated above and this Guarantee is given in place of all other guarantees whatsoever, to the fullest extent permitted by law. In the absence of applicable legislation, this Guarantee will be the end-user's sole and exclusive remedy against IPSES.

### General Provisions

IPSES makes no express warranties or conditions beyond those stated in this warranty statement. IPSES disclaims all other warranties and conditions, express or implied, including without limitation implied warranties and conditions of merchantability and fitness for a particular purpose.

IPSES's responsibility for malfunctions and defects in hardware is limited to repair and replacement as set forth in this warranty statement.

IPSES does not accept liability beyond the remedies set forth in this warranty statement or liability for incidental or consequential damages, including without limitation any liability for products not being available for use or for lost data or software.

---

<sup>1</sup> With the exclusion of shipping costs for and from IPSES's development office.



**WARNING!**  
**ELECTRICAL DEVICES COULD DAMAGE EQUIPMENT OR PROPERTY OR CAUSE PERSONAL INJURY**

This guide contains instructions and technical features of ALPHA PARTICLE COUNTING SYSTEM **CALPH**.

Read with attention before attempting to use.

It is the responsibility of the technician to undertake all the safety rules provided by the law during the installation and the use of this device.

For any information which is not contained in this guide, please contact:

**IPSES S. r. l. - Via Trieste, 48 - 20020 Cesate (MI) Italy**

Tel. (+39) 02/9906845 - Fax (+39) 02/700403170

<http://www.ipses.com> - e-mail [info@ipses.com](mailto:info@ipses.com)



## TABLE OF CONTENTS

|   |    |
|---|----|
| REVISION HISTORY .....                      | 6  |
| DESCRIPTION .....                           | 7  |
| GENERAL FEATURES .....                      | 8  |
| FRONT PANEL .....                           | 9  |
| REAR PANEL .....                            | 10 |
| OPERATION .....                             | 11 |
| PRINTER .....                               | 13 |
| SAMPLE PLACEMENT .....                      | 16 |
| SAMPLE AND SCINTILLATOR DISC REMOVING ..... | 18 |
| MEASUREMENT .....                           | 19 |
| COINCIDENCE COUNTER .....                   | 22 |
| COMMUNICATION PROTOCOL .....                | 23 |
| MAINTENANCE .....                           | 25 |
| TECHNICAL FEATURES .....                    | 25 |
| OTHER LABORATORY DEVICES .....              | 27 |
| CONTACTS .....                              | 28 |
| CONTACTS .....                              | 28 |
| SUPPORT INFORMATION .....                   | 29 |
| PROBLEM REPORT .....                        | 29 |
| ENGINEERING PROBLEM REPORT .....            | 30 |



## REVISION HISTORY

### Hardware revision history

| Revision/<br>Date         | Change description     | Author       |
|---------------------------|------------------------|--------------|
| 01.01.0000<br>March, 2005 | First version Released | Pizzocolo G. |

### Manual revision history

| Revision/<br>Date           | Change description   | Author     |
|-----------------------------|--|------------|
| 01.00.0000<br>March, 2005   | First version Released   | Mancuso C. |
| 01.01.0000<br>October, 2009 | Changed voltage output, upgraded contacts, other minor changes | Mancuso C. |



## DESCRIPTION

The alpha particle counting system *Calph* is a stand-alone low level alpha counter used for accurate alpha dose measurements.

It is composed of two principal units, a control and power unit, and a detector unit.

The **control and power unit** consists of:

- Integrated High Voltage power supply for Photomultiplier (PMT)
- Signal shaping amplifier
- Two single-channel analysers with adjustable LLD values
- One delayed coincidence unit
- CPU for system control
- LCD display 2 lines x 20 characters
- 42 characters per line impact dot matrix printer

The **detector unit** consists of:



- Head-on 52 mm Photomultiplier (PMT)
- Light safe enclosure
- High Voltage lock to prevent damage of the PMT caused by accidental opening
- Sample holder

The two single channel analyzer and the time coincidences unit, which act on the SCA1, allow to discriminate decays of Th232 chain, rejecting fast coincidence pairs due to U238 chain.

Measure items also supplied with the system:

- ZnS scintillator discs on mylar



## GENERAL FEATURES

The alpha particle counting system *Calph* offers:

- LCD display two lines 20 characters backlighted
- 2K internal RAM with battery and timekeeper
- printer for measure report or periodic prints
- remote RS232 serial interface
- monitor test outputs
- High Voltage status led
- Measure status led
- Adjust knob to select the value of the parameters
- Measure time corrected for dead time
- Power down recovery

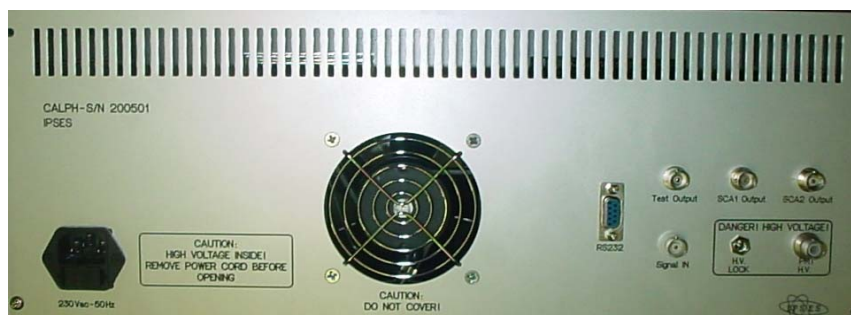
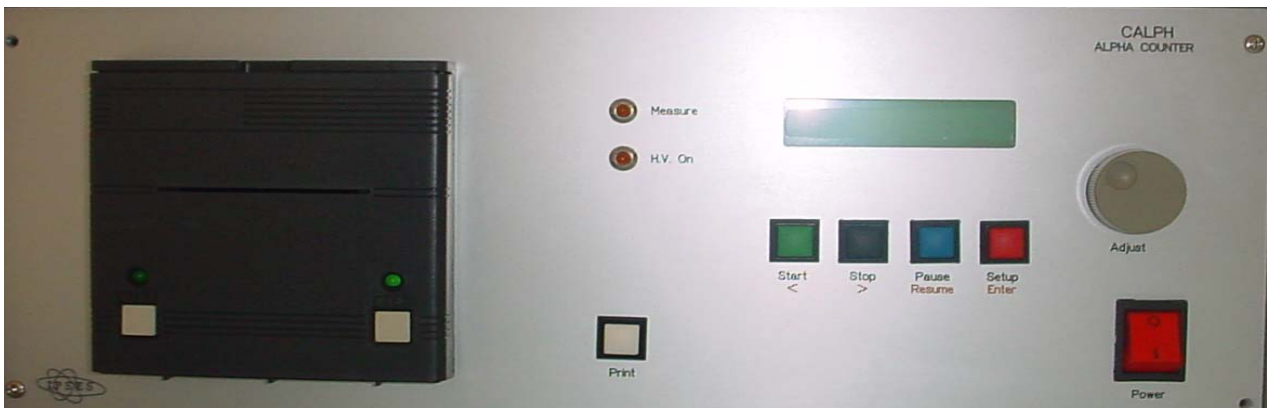

## FRONT PANEL

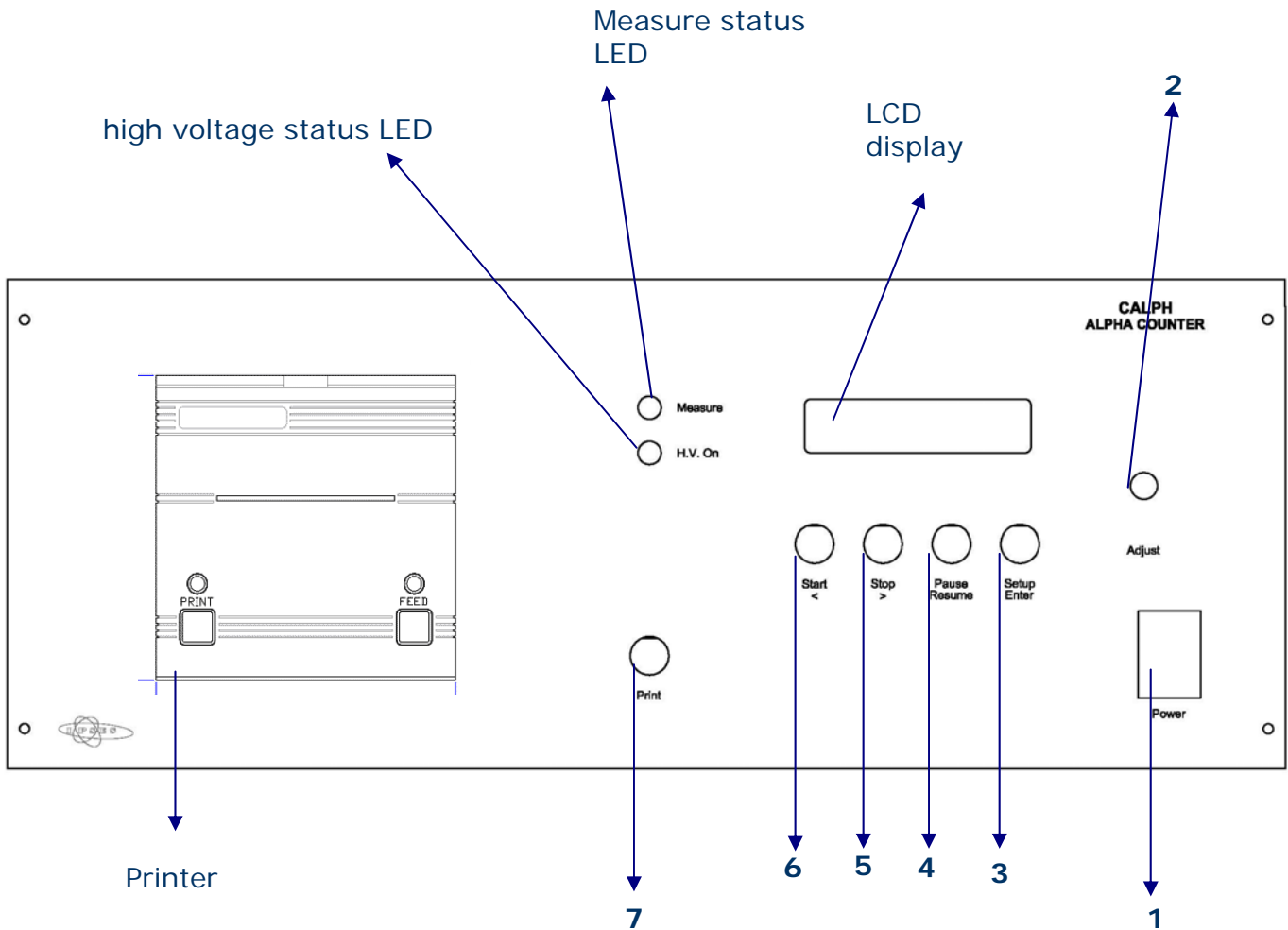

1. Power on/off
2. Adjust knob
3. Setup Key  
Enter Key in the setup mode
4. Pause Key  
Resume key in the setup mode
5. Start Key  
Left arrow key in the setup mode
6. Stop Key  
Right arrow key in the setup mode
7. Print key



**REAR PANEL**

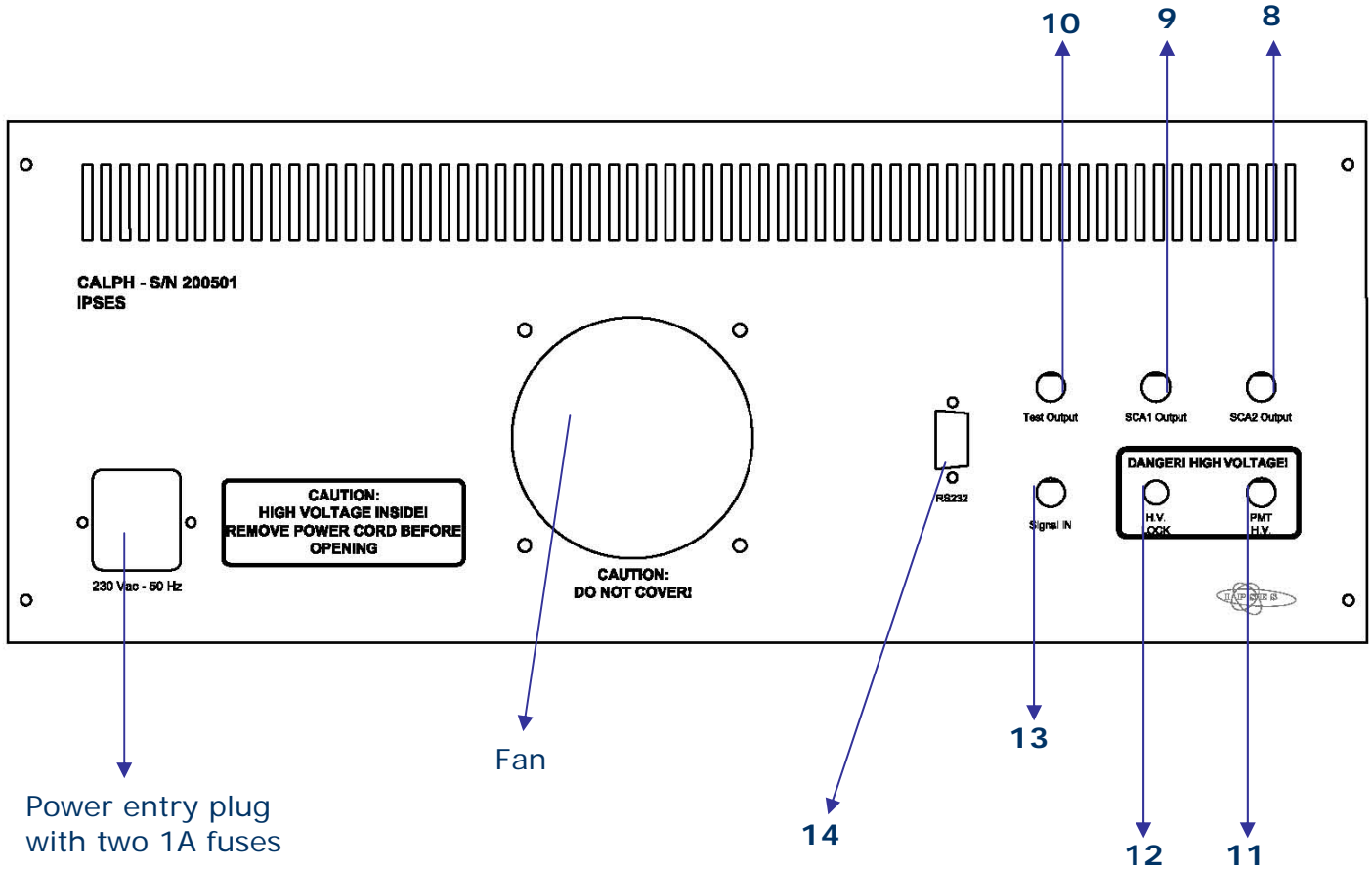

- 8. BNC output connector for SCA2 (single channel analyzer 2)
- 9. BNC output connector for SCA1 (single channel analyzer 1)
- 10. BNC test output connector
- 11. HV-BNC output connector for PMT
- 12. Circular connector for HV interlock
- 13. BNC input connector for the photomultiplier signal
- 14. Serial port (PC connection)



## OPERATION

### Power on and shut down

To turn on the unit, use the rightmost switch on the front panel (see n. 1 on the drawing). After the logo presentation, the unit is ready to start the measure with the setup parameters previously selected.

### Setup

Four double functions keys are present on the front panel (see n. 3 to n. 6 on the drawing).

To modify the measure parameters, press the **setup key** (n. 3). To select the desire parameters, press the **arrow keys** (n. 5 and n. 6).

The current value of each parameter is shown. To change this value act on the **adjust knob** (n. 2): a clockwise rotation will increase it, while counter clockwise rotation will decrease it. To accept the selected value, push either the **enter key** (n. 3) or **the arrow keys**.

Pushing the **enter key** closes the setup menu, whereas acting on the **arrow keys** shows the next or the previous setup parameter. The **resume key** (n. 4) closes the setup menu without saving the values. Pressing the **setup key** will show every time the last edited parameter.

The selected parameters are always saved in the internal RAM.

To set the parameters to **default values**, power on the unit while pressing the **stop key** (n. 6).

### Modifiable parameters:

- Energy threshold for single channel analyzer 1 [20 up to 5000 mV]
- Energy threshold for single channel analyzer 2 [20 up to 5000 mV]
- Time window anticoincidence [2 up to 20 ms]
- Time window coincidence [100 up to 400 ms]
- PMT high voltage [500 up to 1500 V]
- Measure time
  - hours [0 up to 48]
  - Minutes [0 up to 59]
  - Seconds [0 up to 59]
- Periodic print enabled [YES-NO]
- Periodic print period [30 – 60 – 90 - 120 minutes]<sup>2</sup>

<sup>2</sup> This parameter is available only when the periodic print is enabled.



It is possible, through the correspondent outputs on the rear panel, to check if the selected energy threshold is correct in connection with the input signal.

#### Factory default parameters:

- Energy threshold for SCA 1 [1200 mV]
- Energy threshold for SCA 2 [1500 mV]
- Time window anticoincidence [20 ms]
- Time window coincidence [300 ms]
- PMT high voltage [1000 V]
- Measure time [24:00:00]
- Periodic print enabled [NO]
- Periodic print period [120 minutes]

#### Internal clock setup

To check time and date of the internal clock, power on the unit while pressing the **setup key** (n. 3). First, the time will be presented: select the field to modify using the arrow keys and set up the correct value acting on the adjust knob. To save the new time values, press the **enter key** (n. 3): now the date setup menu will be shown. To close the setup menu without saving the values, press the **resume key** (n. 4). To change the date, once the date setup menu is presented, select the field to modify using the arrow keys and set up the correct value acting on the adjust knob. Press the **enter key** to save the new values or the resume key to quit without saving the changes.

#### Power down recovery

The **internal RAM**, equipped with a battery, allows to resume a measure interrupted because of an accidental power interruption. No manual operation is required. **To reset** the measure condition, power on the unit while pressing the **stop key** (n. 6): this operation sets the parameters to the default values too.

#### Interfacing

The alpha counting system **Calph** is equipped with a serial interface RS232. Using the 9pin sub-D connector on the rear panel, it is possible connecting the unit to a Personal Computer.



## PRINTER

*Calph* is equipped with an integrated 42 characters per line impact dot matrix printer. The printer has a speed of 1.0 lines/sec. The print method is impact shuttle.

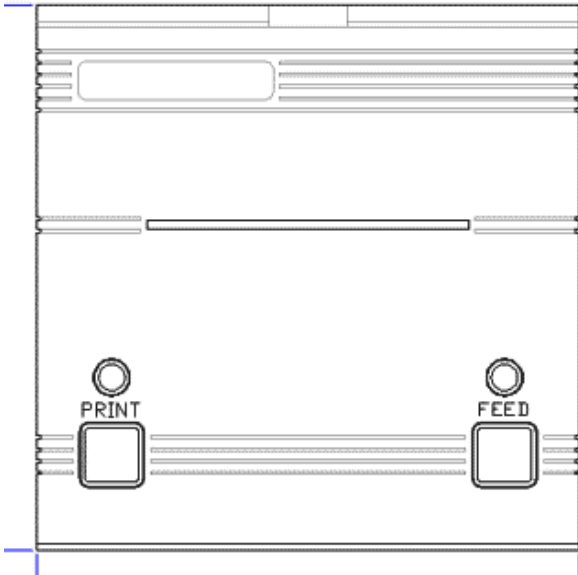

### Print setup

Two print functions are available from the setup menu:

- Periodic print enabled [YES-NO]
- Periodic print period [30 – 60 – 90 – 120 minutes]

Default parameters are:

- Periodic print enabled [NO]
- Periodic print period [120 minutes]

**Select** the chosen **parameters** through the **arrow keys**. To modify the value, act on the **adjust knob**, then press the **enter key**. To quit the setup without saving the new values, press the **resume key**.

If the **periodic print** is **enabled**, it is possible to choose four different periods [30 – 60 – 90 – 120 minutes] to have a periodic print report during measure.

In this case, at the start of the measure, the selected parameter are printed. Then, when the selected period is passed, the elapsed live time and the incremental counts (from the start or from the last periodic print) are printed, so it is possible to check if during that time some spikes or noise were present.



When the system is paused or resumed, by the **print key** present on the front panel (see key n. 7 on the drawing) it is possible to select a different time for periodic report without entering in the setup menu: pressing once the key, a periodic time is printed. Every time the key is pressed the periodic time is incremented and printed.

If the **periodic print** is **not enabled**, pressing the **print key** on the front panel (n. 7) it is possible to have a report of the current measure according the values of the selected parameters: the total counts, the counting rate in cpm (counts per minutes) end the standard deviation also in cpm.

When the measure time is finished a final report is always printed which includes: the measure parameters, the total counts, the counting rate and the standard deviation in cpm.

If the **measure** is **stopped** through the **stop key** (n. 6), the measure report is printed only if the stop key is released within a second.

During **testing measure** no final report is printed, only if the periodic print is enabled it is possible to have a start report.

If no measure is in progress, the print key allows to print the report of the last measure executed.

## CAUTION !

The printer is already configured for working with the alpha counter. **Do not change the default parameters** (so do not press both buttons n. 15 and 16 when the printer is switched on).

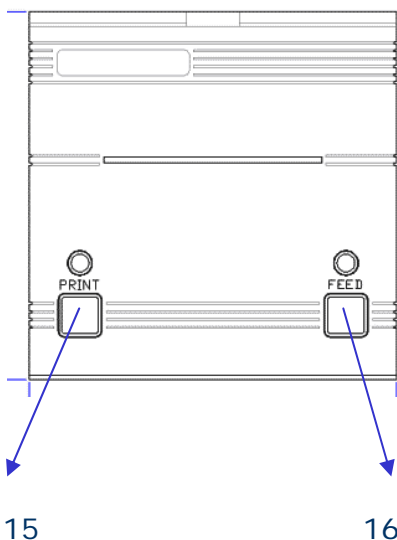

## Paper roll and ink ribbon cartridge replacement

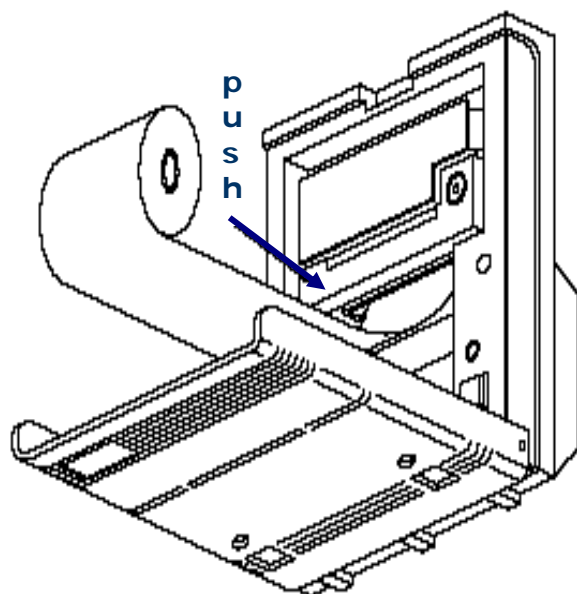

To change the **paper roll**, open the printer and insert the new roll as show in the drawing above. To facilitate the insertion of the new roll, it will help to cut the leading edge of the paper at an angle. Push the line feed button on the printer unit (n. 16) until the paper is correctly positioned.

To change the **ink ribbon cartridge**, first remove the used cartridge pushing its left side (as showed by the arrow and the word "push" in the drawing above), then insert the new cartridge in its seating until you feel it snaps into position. It will help to turn the knurled button on the right side of the cartridge clockwise to tension the ribbon before printing.

## Paper roll and ink cartridge refill

Kind of **paper**: normal in rolls. Width: 57,5 mm ( $\pm$  0,5 mm). Thickness: 0,060 + 0,085 mm. Maximum outside roll diameter 50 mm, minimum 12, 5 mm.

**Ink ribbon cartridge**: cartridge ERC 09 or ERC 22. Colour available: purple or black. Life: ERC 09 = 250.000 characters ; ERC 22 = 1.000.000 characters.

All refills, both paper rolls and ink cartridges, can be supplied directly by IPSES.

## Autotest

To print out the self-test, push the FEED button (n. 16) and switch the printer on. The printer will print the character sequence with the information on the default parameters. If the FEED button is released before the end of the self-test, the self-test will be execute just once, then the printer is ready to receive data. If the button is held down, the self-test will be repeated.



## SAMPLE PLACEMENT

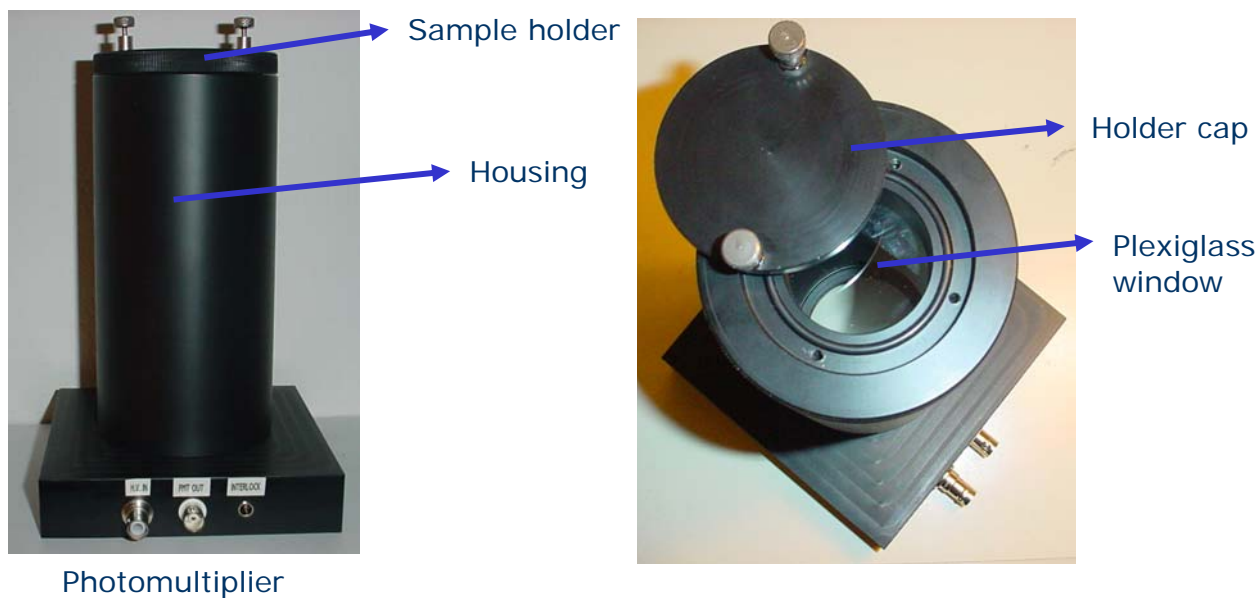

To place the sample inside the Photomultiplier (PMT), take off the sample holder (the upper part of the PMT) from the housing as shown in the picture below (Fig. 1)



Fig. 1

Fig. 2 and Fig. 3



Put the sample holder of the PMT on a level plane so that its plexiglass window lays down perfectly, then unscrew the two screws on the top and open the holder cap (fig. 3).

Place carefully a scintillator disc inside the sample holder with its ZnS surface toward the top (fig. 4). Make sure the disc perfectly lays down on the plexiglass window, then put the powdered sample on the scintillator spreading the powder evenly (Fig. 5).

Close and screw the holder cap, then replace the sample holder on the housing.



Fig. 4



Fig. 5

Each ZnS scintillator disc allows to analyse only one sample: after the measurement the disc will be contaminated by the powder and, for this, it can be re-used only for repeating the analysis on the same sample.



## SAMPLE AND SCINTILLATOR DISC REMOVING

To remove the sample from the PMT, take off the sample holder and open the holder cap as described in the upper section 'Sample placement'.

Take off the powder turning upside down the holder, then place the holder on a level surface.

Carefully remove the scintillator disc using a small suction cup. During this operation, make sure the plexiglass window perfectly lays down on the level plane to avoid stresses which could detach the plexiglass from the holder.



If some ZnS particles are remained on the suction cup, clean it with a soft cloth.



## MEASUREMENT

### Starting

From the rear panel, connect the input signal (n. 13), PMT HV (n. 11) and the HV Lock (n. 12) connectors to the control unit through the correct cables supplied with the system.

Connect the power cord and then power on the unit. Now the system is ready to start a measurement with the factory default parameters; to change these values, see the setup section.

### Calibration

To calibrate the alpha counter use a known activity sample.

Place a ZnS scintillator disc inside the sample holder, then put the sample on the disc. Close the holder cap, select the correct measure parameters, then push the start key to begin the measurement. If the sample holder is properly closed, the high voltage will be on and the HV status led on the front panel will light. The measure status LED will blink for a few seconds until the high voltage will be stabilized, then LED light will be on and the measure properly starts.

On the display the total counts of the two Single Channel Analyzers (SCA 1 and SCA 2) and the coincidences counts are shown. Pushing the enter key once or two times it is possible to see on the display the actual counting rate or the elapsed live time. By connecting a scope to the BNC test output connector (see n. 10 on the rear panel

drawing) or to SCA1 and SCA2 outputs (n. 8 and 9) the correct working of the instrument can be checked.

### Measure

Select the measure parameters as described in the OPERATION section (p. 11). Place a ZnS scintillator disc inside the sample holder, then put the sample to be measured on the disc. Close the holder cap.

To **start** the measurement, press the start key. If the detector unit is properly closed the HV is on and its status LED lights. The measure status LED will blink for a few seconds until the high voltage will be stabilized, then LED light will be on and the measure properly starts. On the display the total counts of SCA 1 and SCA 2 and the coincidences counts are shown (see p. 19 the "time coincidence window" paragraph for details). Pushing the enter key once or two times it is possible to see on the display the actual counting rate expressed in cpm or the elapsed live time.

To **stop** the measure, use the stop key: in this case measure status LED is switched off and the HV is shut down as show also by its status LED. If enabled, at this time a measure report is printed (see the correspondent section).

During a measurement it is possible to **stop temporarily** the process using pausing key: this condition will be indicated by the blinking of the measure status LED. The HV



will be shut down as indicated by its status LED. At this time is possible to stop the measure pressing the stop key or to resume the measure (using the resume key).

When the **measure time ends** the HV will be shut down, both LEDs on the front panel will be switched off, the measure report will be printed if required (see the printer section p. 12) and the count rates will be displayed. Then the system will be ready to start with a new measurement.

At the end of a measure, pressing the pause key will clear the display.

If during the measure the sample holder is accidentally opened, a security switch inside the housing will interrupt the high voltage, pausing the system. After closing the sample holder cap, push the resume key to restart the measure or use the stop key to stop it.

### Test measure

When the start key is pressed a wait message appears on the display for few moments. If during this time the pause key will be pushed, the **test measure function** is selected. While working in this operation mode, only the total counts will be displayed.

The test measure function allows the possibility of changing dynamically both the SCA 1 and SCA 2 energy threshold and the High Voltage of the photomultiplier. Once entered in this operation mode, press the setup key to enter in the setup menu (see the correspondent section to select new values). When the setup menu will be closed, the measure can restart. If the HV was changed, the correspondent status LED will blink for a few seconds (just the time of stabilizing it). To end the measure, press the stop key. If during the measure the sample holder is accidentally opened, a security switch inside the housing will interrupt the high voltage, and the measure stops immediately.



Print measure report

```

Measure # 27
Measure started: 06 Apr 1999 18:03
Measure Live Time: 47:30:00
Threshold: SCA1 50 mV SCA2 200 mV
Pmt High Voltage: 1000 V
Coincidence Window: 20 - 300 ms

Incremental counts:
Time      SCA1      SCA2      coinc.
01:00    1.20E+03  1.02E+03  1.19E+02
02:00    1.16E+03  9.98E+02  1.12E+02
03:00    1.07E+03  9.05E+02  1.03E+02
04:00    1.15E+03  9.85E+02  1.12E+02
05:00    1.09E+03  9.42E+02  1.15E+02
06:00    1.19E+03  1.05E+03  1.35E+02
07:00    1.12E+03  9.43E+02  1.12E+02
08:00    1.17E+03  9.91E+02  1.17E+02
09:00    1.16E+03  9.96E+02  1.23E+02
10:00    1.11E+03  9.62E+02  1.15E+02
11:00    1.10E+03  9.50E+02  1.06E+02
12:00    1.15E+03  9.79E+02  1.20E+02
13:00    1.16E+03  1.01E+03  1.20E+02

MEASURE REPORT
Measure # 27
Remarks.....

.....

Measure started: 06 Apr 1999 18:03
Measure ended : 07 Apr 1999 07:28
Measure Live Time: 13:25 (hh:mm)
Threshold: SCA1 50 mV SCA2 200 mV
Pmt High Voltage: 1000 V
Coincidence Window: 20 - 300 ms

Total counts Count rate Std. dev
              [cpm]      [cpm]
SCA1: 1.530E+04 1.900E+01 1.536E-01
SCA2: 1.312E+04 1.629E+01 1.423E-01
Coinc: 1.547E+03 1.922E+00 4.886E-02
Measure ended by user
    
```

Measure data:  
 Measure number;  
 date and hour;  
 measure live time;  
 set parameters.

Incremental counts:  
 periodic print report during measure.  
 Available periods : 30 – 60 – 90 – 120 minutes.  
 It indicates the counts during the selected period  
 at the moment of the print (SCA1; SCA2 and  
 coincidence counts)

Measure Report:  
 space for personal remarks

Measure data:  
 measure started and ended;  
 measure live time;  
 set parameters.

Final counts (SCA1, SCA2, coincidence counts):  
 - on the first column there are the total counts  
 - on the second one there is the count rate  
 (counts per minute)  
 - on the last column there is the standard  
 deviation (counts per minute)







## COINCIDENCE COUNTER

Besides the two independent SCA units, calph features a smart time-coincidence unit. The digital output of SCA1 is the input of this unit. Every time an event is counted by SCA1, it triggers a time window defined by  $t_1$  and  $t_2$ , the delays from the trigger time  $t_0$  for the start and the stop of the time window, respectively. If a second event is counted by SCA1 with a delay falling in the predefined time window, the coincidence counter is incremented (see figure below).

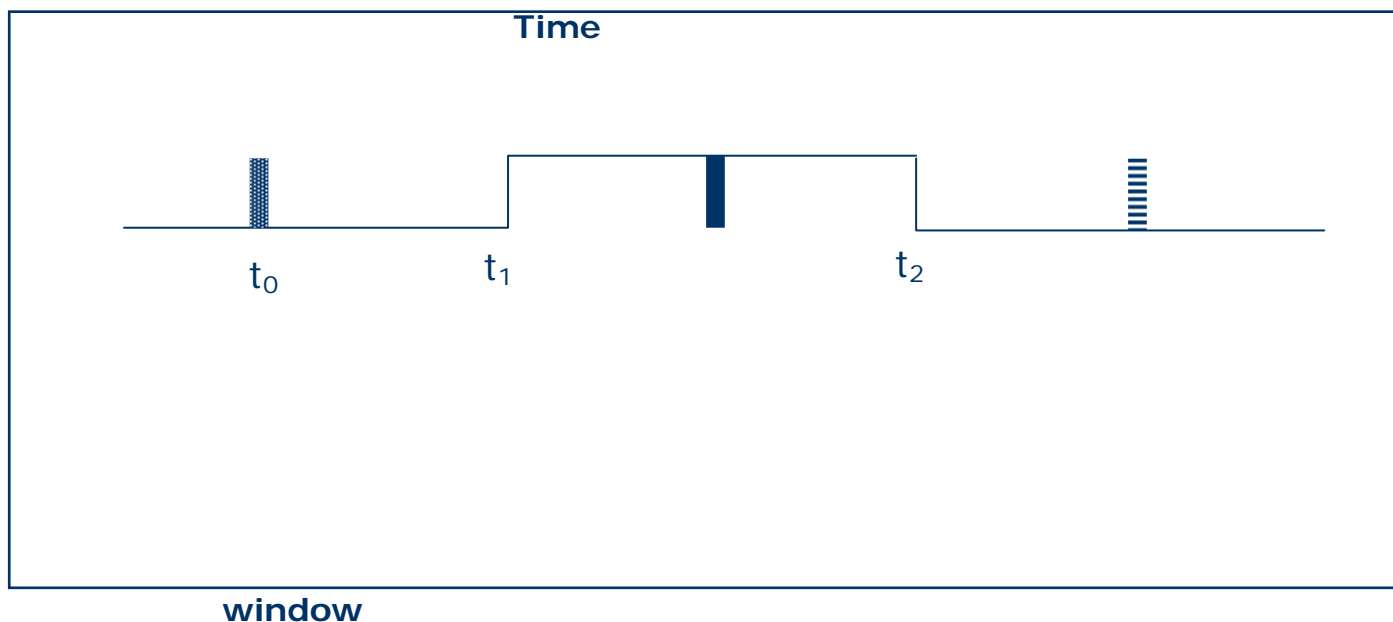
The two delays  $t_1$  and  $t_2$  are adjusted using the time coincidence window setup as described at page 11 and 12.

This functionality allows differentiating between the alpha activities of two different radioisotopic chains. A typical application is to evaluate the ratio of  $\text{Th}^{232}$  and  $\text{U}^{238}$  alpha activity in a sample.



-  = start event
-  = *good* coincidence, coincidence counter incremented
-  = false coincidence, coincidence counter unchanged



## COMMUNICATION PROTOCOL

The messages exchanged over the serial communication interface are ASCII text strings. The commands are case sensitive. The parameters (n, h, m, s) have to be written as decimal numbers. The message terminator is the character <CR> (Hex 0a), other control characters are ignored. The data format is 1 start bit, 8 data bit, 1 stop bit, no flow control. The following is the complete list of the communication messages.

### Setup commands

- **E1,n** SCA 1 energy threshold; **n** is a 16 bit word and the measure unit is mV
- **E2,n** SCA 2 energy threshold; **n** is a 16 bit word and the measure unit is mV
- **V,n** High Voltage for PMT; **n** is a 16 bit word and the measure unit is V
- **W,n** time window coincidences; **n** is a 16 bit word and the measure unit is ms
- **D,n** delay for coincidences; **n** is a 8 bit word and the measure unit is ms
- **T,h,m,s** measure time expressed in hours, minutes and seconds; **h,m,s** are three 8 bit words of two characters.
- **pn** periodic print; **n** is a 8 bit word and it means:
  - **0** periodic print disabled
  - **1** periodic print enabled with a period of 30 minutes
  - **2** periodic print enabled with a period of 60 minutes
  - **3** periodic print enabled with a period of 90 minutes
  - **4** periodic print enabled with a period of 120 minutes

Different command characters are ignored.

Setup values are stored in non-volatile memory. It is possible to modify the setup values when no measure is in progress, apart from the special case of "test measure" enabled (see pag. 17).

### Measure control

- **G** starts the measure
- **S** stops the measure
- **P** pauses the measure
- **R** resumes the measure



## Data readout

The next messages produce an immediate answer from the unit:

- **C** requests the total counts and the elapsed live time. The answer will be three 32 bit words and two 8 bit words separated by commas representing: the total counts of SCA 1 and SCA 2, the coincidences and the elapsed live time in hours and minutes. If the measure is ended, this command shows the final values of the last measure
- **U** requests the status of the unit.

**The status request message ("U")** forces the device to return a byte (2 hex characters) representing the actual status of the unit.

|               |              |  |
|---------------|--------------|--|
| System status | = <b>0</b>   | system ready   |
|               | <b>Bit 0</b> | measure in progress  |
|               | <b>Bit 1</b> | measure paused   |
|               | <b>Bit 2</b> | measure starting (delay for HV stabilize after resume command) |
|               | <b>Bit 3</b> | measure resuming (delay for HV stabilize after resume command) |
|               | <b>Bit 4</b> | system error   |

If the error bit is high (i. e. if it answers with a code like **10**), then another error code is added after a comma (for example **10,02**)

|                 |              |                                   |
|-----------------|--------------|-----------------------------------|
| Error condition | = <b>0</b>   | no error                          |
|                 | <b>Bit 0</b> | sample holder cap open with HV on |
|                 | <b>Bit 1</b> | syntax error in the host message  |



## MAINTENANCE

### Detector unit

The only parts of the system which need some maintenance are the sample holder and the PMT plexiglass window. Clean them periodically with a soft cloth. When they are opaque, replace them with the spare ones supplied with the system. The new sample holder window must be glued with a drop of cynolit or epoxy. To change the PMT window the whole detector must be dismounted. It does not need to be glued.

## TECHNICAL FEATURES

**Power supply:** 230 Vac +/- 10% 50Hz (on request, it is available with any supply voltage)

**Max Consumption:** 50 VA

**Operating temperature:** 0-50°C

**Operating humidity:** 10%-80%

**High Voltage output:** adjustable between -320V and -1.995V

**Output current:** 2mA maximum

**Dimensions:** control unit: 470,8 mm x 191,6 mm x 312,6 mm (h x l x p)  
PMT housing: 220 mm height – base: 140 mm x 140 mm



|                 |                              |                                |
|-----------------|------------------------------|--------------------------------|
| <b>Printer:</b> | <b>print method</b>          | impact shuttle (dot matrix)    |
|                 | <b>Print direction</b>       | horizontal                     |
|                 | <b>Print speed</b>           | 1.0 lines/second               |
|                 | <b>Paper feed</b>            | 2.3 lines/second               |
|                 | <b>Print quality</b>         | full graphic bit image         |
|                 | <b>Characters per line</b>   | 42 (normal)                    |
|                 | <b>Print area width</b>      | 47 mm                          |
|                 | <b>Horizontal resolution</b> | 5.26 dots/mm                   |
|                 | <b>Vertical resolution</b>   | 2.7 dots/mm (0.37 mm/dot line) |
|                 | <b>Dots per line</b>         | 252                            |



## OTHER LABORATORY DEVICES



IPSES operates in the lab instrumentation sector, designing customized electronic solutions, not only by producing and delivering scientific instrumentation, but also through efficient and qualified support, courses and lectures on the basics on principles and methods, and guiding our customers in choosing the right instrument and learning how to use it most efficiently.

### thermoluminescence laboratory

IPSES designs, produces and markets all the instrumentation required for a thermoluminescence lab:

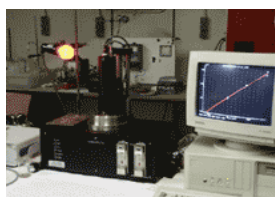

- vacuum oven to heat the sample
- thermoregulation unit with enough precision to control the heating ramp
- photo-detector (made up by signal acquisition stage, a sensitive photomultiplier and a high-voltage power supply for the photomultiplier) capable of acquiring the thermoluminescence signal from the sample at different temperatures
- device capable of keeping an inert gas inside the vacuum oven
- dryer and an ultrasonic bath to prepare the samples
- software to control analysis system



### HiVo

HiVo is a device especially conceived to furnish an adjustable elevated voltage up to -1.995V. Although it is mainly used to supply photomultipliers, HiVo can be employed with any device needing high voltage and low current supply.

HiVo can be customized to serve our clients' needs to the best: for this, on request, HiVo is available with any supply voltage and positive and/or negative output voltage. HiVo is equipped with a 3,5 digit LCD display showing the output voltage. A 10-turn potentiometer sets the voltage and assures precision and stability.

For further information, please visit our website <http://www.ipses.com>.



## CONTACTS

**IPSES s.r.l.** conceives, projects and markets electronic and scientific instruments. The customized planning of our devices allows us to answer specific needs for customers asking for embedded systems. **IPSES** clients enjoy access to a dedicated project engineering team, available as needed.

Our pool consists of highly competent professionals whose experience in this field is extremely strong. Thanks to constant updating and technical development, **IPSES** is a leading company, combining the dynamism of a young group into the competence and reliability of a qualified staff.

### **IPSES s. r. l.**

#### **Research and development office:**

via Trieste, 48  
20020 Cesate (MI)  
Italy



**tel.** +39 02 99068453  
**fax** +39 02 700403170  
**e-mail:** [info@ipses.com](mailto:info@ipses.com)  
**http://**[www.ipses.com](http://www.ipses.com)



---

## **SUPPORT INFORMATION**

The customer is at liberty to contact the relevant engineer at IPSES S.r.l. directly.

A call can be logged in a variety of ways:

|           |   |  |
|-----------|---|--|
| Telephone | : | ++39 02 99068453   |
| Fax       | : | ++39 02 700403170  |
| Email     | : | <a href="mailto:support@ipses.com">support@ipses.com</a> |

## **PROBLEM REPORT**

The next page is a standard template used for reporting system problems. It can be copied and send as a fax. Alternative bugs may be reported by emails, in this case please insure that the mail contains similar information as the *Engineering Problem Report* form.



## ENGINEERING PROBLEM REPORT

### Problem describer

|         |      |   |
|---------|------|---|
| Name    |      | <b>IPSES s.r.l.</b><br>Via Trieste, 48<br>Cesate (MI)<br>Italy<br>Fax ++39 02/700403170<br>e-mail<br><i>support@ipses.com</i> |
| Company |      |   |
| Date    | Tel. |   |

### Product

|      |         |            |
|------|---------|------------|
| Name | Version | Serial No. |
|------|---------|------------|

### Report Type (bug, change request or technical problem)

|                   |                          |          |                          |
|-------------------|--------------------------|----------|--------------------------|
| Major bug         | <input type="checkbox"/> | Urgency: |                          |
| Minor bug         | <input type="checkbox"/> | High     | <input type="checkbox"/> |
| Change request    | <input type="checkbox"/> | Medium   | <input type="checkbox"/> |
| Technical problem | <input type="checkbox"/> | Low      | <input type="checkbox"/> |

### Problem Description

### Reproduction of Problem

### IPSES s.r.l. Action notes

|             |      |            |        |
|-------------|------|------------|--------|
| Received by | Date | Report No. | Action |
|-------------|------|------------|--------|



(Code ALFA01-9501 Rel. 01.01.0000)

**IPSES S.r.l.**

Via Trieste, 48  
20020 CESATE (MI) - ITALY  
Tel. (+39) 02/99068453  
Fax (+39) 02/700403170  
e-mail: [info@ipses.com](mailto:info@ipses.com)  
[support@ipses.com](mailto:support@ipses.com)

