

WEB-ADIO-WiFi Control Unit  
USER MANUAL

Rel. 01.00.0002

(Hardware code: WEB-ADIO-WiFi)

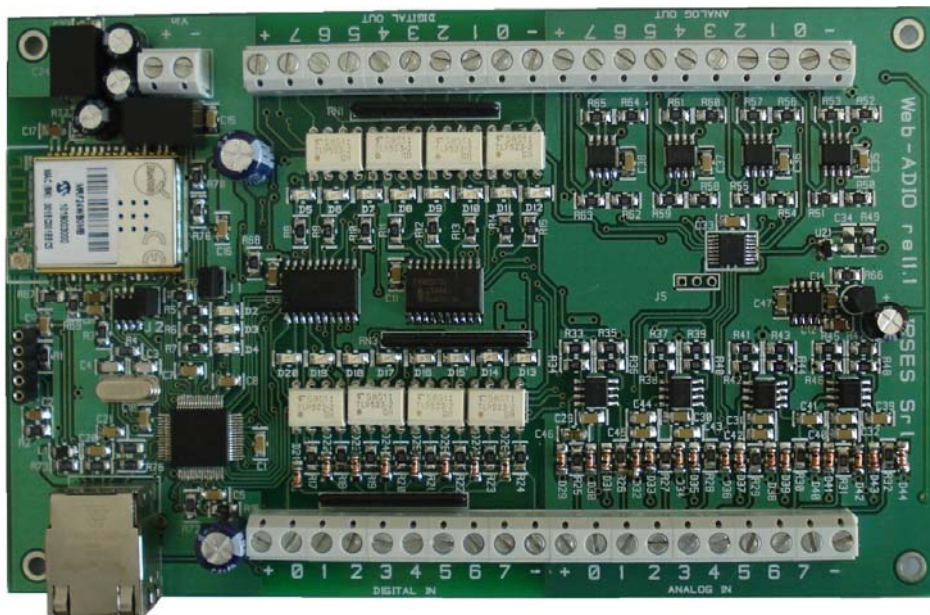



---

Information provided in this manual is property of IPSES S.r.l. and must be considered and treated as confidential. This publication can only be reproduced, transmitted, transcribed or translated into any human or computer language with the written consent of IPSES S.r.l.

Information in this documentation has been carefully checked and is believed to be accurate as of the date of publication; however, no responsibility is assumed of inaccuracies. IPSES will not be liable for any consequential or incidental damages arising from reliance on the accuracy of this documentation.

Information contained in this manual is subject to change without notice and does not represent a commitment on the part of IPSES. The design of this instrument is subject to continue development and improvement. Consequently, the equipment associated to this document may incorporate minor changes in detail from the information hereafter provided.

All brand or product names are trademarks or registered trademarks of their respective holders.

This manual in English is the original version.

Printed in Italy

Copyright © 2009-2016 IPSES S.r.l.

All rights reserved.





## GUARANTEE

IPSES warrants to the end-user in accordance with the following provisions that its branded hardware products, purchased by the end-user from IPSES company or an authorized IPSES distributor will be free from defects in materials, workmanship and design affecting normal use, for a period of one year as of the original purchase date. Products for which proper claims are made will, at IPSES's option, be repaired or replaced at IPSES's expense<sup>1</sup>.

### Exclusions

This Guarantee does not apply to defects resulting from: improper or inadequate installation, use or maintenance; actions or modifications by unauthorized third parties or the end-user; accidental or wilful damage or normal wear and tear.

### Making a claim

Claims must be made by contacting IPSES office within the guarantee period.

Please, contact:

IPSES S.r.l. - Via Suor Lazzarotto, 10 - 20020 Cesate (MI) Italy  
Tel. (+39) 02 39449519 – (+39) 02 320629547  
Fax (+39) 02 700403170  
<http://www.ipses.com> - e-mail: [support@ipses.com](mailto:support@ipses.com)

### Limitation and Statutory Rights

IPSES makes no other warranty, guarantee or like statement other than as explicitly stated above and this Guarantee is given in place of all other guarantees whatsoever, to the fullest extent permitted by law. In the absence of applicable legislation, this Guarantee will be the end-user's sole and exclusive remedy against IPSES.

### General Provisions

IPSES makes no express warranties or conditions beyond those stated in this warranty statement. IPSES disclaims all other warranties and conditions, express or implied, including without limitation implied warranties and conditions of merchantability and fitness for a particular purpose.

IPSES's responsibility for malfunctions and defects in hardware is limited to repair and replacement as set forth in this warranty statement.

IPSES does not accept liability beyond the remedies set forth in this warranty statement or liability for incidental or consequential damages, including without limitation any liability for products not being available for use or for lost data or software.

---

<sup>1</sup> With the exclusion of shipping costs for and from IPSES's development office.





**WARNING!**  
**ELECTRICAL DEVICES COULD DAMAGE EQUIPMENT OR PROPERTY OR CAUSE PERSONAL INJURY**

This guide contains instructions and technical features of the WEB-ADIO-WiFi Control Unit.

Read with attention before attempting to install.

It is the responsibility of the technician to undertake all the safety rules provided by the law during the installation and the use of this device.

For any information which is not contained in this guide, please contact:

**IPSES S.r.l. - Via Suor Lazzarotto, 10 - 20020 Cesate (MI) Italy**

Tel. (+39) 02 39449519 – (+39) 02 320629547

Fax (+39) 02 700403170

<http://www.ipses.com> - e-mail: [support@ipses.com](mailto:support@ipses.com)





## TABLE OF CONTENTS

TABLE OF CONTENTS .....	5
REVISION HISTORY .....	6
GENERAL FEATURES .....	7
CARD DESCRIPTION .....	8
FUNCTIONING MODES .....	16
LED STATUS .....	16
POWER SUPPLY .....	17
NETWORK INTREFACES – MAC ADDRESSES .....	18
ETHERNET MODULE .....	18
WiFi MODULE.....	18
NETWORK SERVICES.....	20
ADDRESSES CONFIGURATION.....	21
<i>http</i> SERVER .....	23
<i>telnet</i> SERVER.....	35
SNMP SERVER.....	39
PROBLEMS RESOLUTION:.....	42
DEMO SOFTWARE .....	43
TCP/IP ADDRESS CONFIGURATOR SOFTWARE.....	50
ADDRESS CONFIGURATION MODE .....	50
ADDRESS CONFIGURATOR CONTROL PANEL .....	51
PRODUCT CODE .....	54
TECHNICAL FEATURES.....	54
IPSES I/O CARD AVAILABLE MODELS .....	56
CONTACTS .....	60
SUPPORT INFORMATION.....	61
PROBLEM REPORT.....	61
ENGINEERING PROBLEM REPORT.....	62





## REVISION HISTORY

### Manual revision history

Revision/ Date	Change description	Author
01.00.0000 October, 2010	First version Released	Rivolta A.
01.00.0001 June, 2015	Update layout document	Bottaccioli M.
01.00.0002 August, 2016	Added ISO 9001:20015 logo	Bottaccioli M.



## GENERAL FEATURES



WEB-ADIO-WiFi is a control unit integrated on a *European Card Format* (160 x 100 mm – 6,30 x 3,94 inches) equipped with Ethernet and WiFi interfaces.

The card needs an external power supply (from 15V to 32V, continuous current) to operate.

WEB-ADIO-WiFi can acquire and control digital and analogical signals. The digital interface consists of eight optocoupled inputs and eight optocoupled outputs.

The analogical interface can acquire eight inputs and drives eight outputs, both of them included in a 0-10V voltage range and with a resolution of 10bit. Each analogical I/O is individually calibrated.

Analogical and digital channels are reciprocally isolated.

The communication with the card can be supplied with either the Ethernet interface (cabled) or the Wi-Fi 802.11b interface (wireless). The control and the configuration of the device are achieved

thanks to an *http* browser or a *MIB* browser, or a *telnet* client, or using the demo software provided with.

User can set the status of each output at the power-up: this status will be saved in a non volatile memory.

The card allows to perform a firmware upgrade directly from web page, without needs any external hardware or software component.

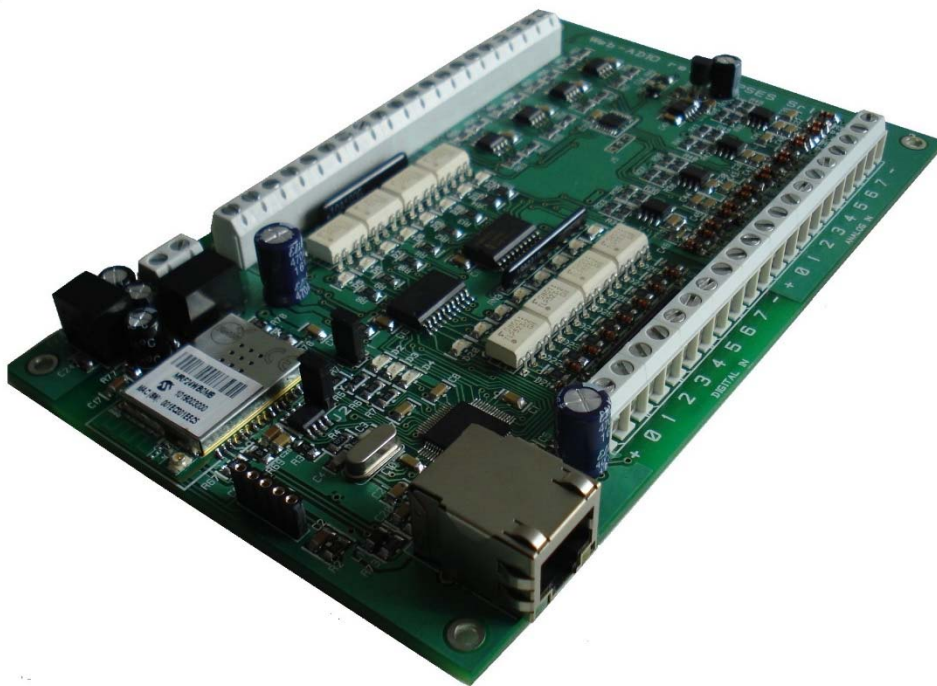

## CARD DESCRIPTION

WEB-ADIO-WiFi card is shown in the picture below: in the upper part of the card the digital and analogical outputs are divided in two groups of eight (numbered from 0 up to 7 on the card serigraphy), and, similarly, in the lower part of the card there are the digital and analogical inputs (numbered and divided in the same way).

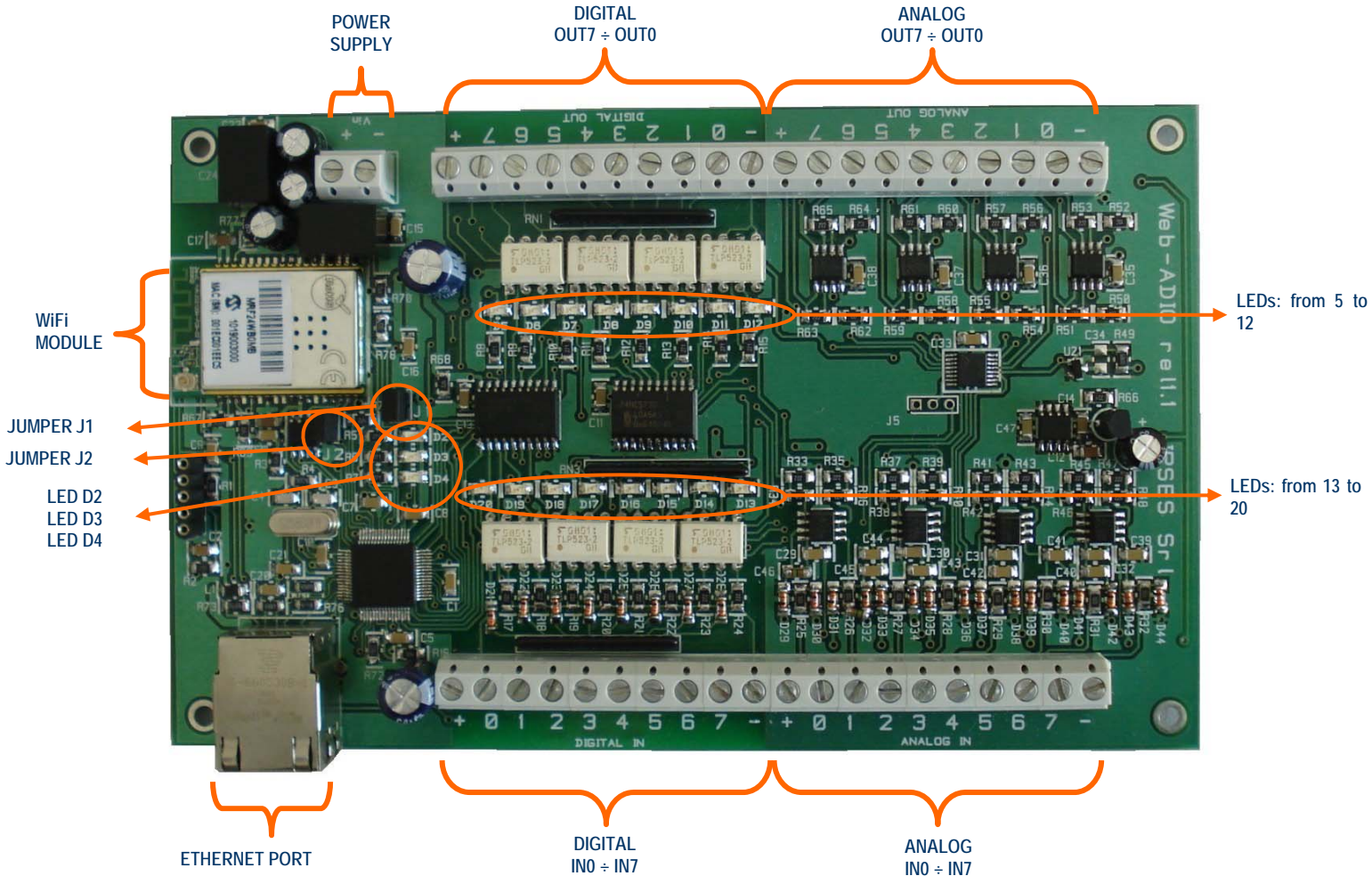

Picture 1: WEB-ADIO card

### Description of the LEDs:

D2	Green LED: Status LED (see relevant paragraph)
D3	Green LED: Status LED (see relevant paragraph)
D4	Red LED: Status LED (see relevant paragraph)
D5	Red LED: digital OUT 7 activated
D6	Red LED: digital OUT 6 activated
D7	Red LED: digital OUT 5 activated
D8	Red LED: digital OUT 4 activated



D9	Red LED: digital OUT 3 activated
D10	Red LED: digital OUT 2 activated
D11	Red LED: digital OUT 1 activated
D12	Red LED: digital OUT 0 activated
D13	Green LED: $V_{high}$ applied at digital IN 7
D14	Green LED: $V_{high}$ applied at digital IN 6
D15	Green LED: $V_{high}$ applied at digital IN 5
D16	Green LED: $V_{high}$ applied at digital IN 4
D17	Green LED: $V_{high}$ applied at digital IN 3
D18	Green LED: $V_{high}$ applied at digital IN 2
D19	Green LED: $V_{high}$ applied at digital IN 1
D20	Green LED: $V_{high}$ applied at digital IN 0

#### Description of the jumper:

J1	Jumper to select the network interface: if the jumper is inserted the Ethernet interface (RJ45 connector) is active, else the wireless interface is active (WiFi module). To enable the network interface change, the user must shutdown and repower the card.
J2	Reset of settings with factory parameters restoration if jumper is insert before the power-up, or Address Configuration mode if jumper is inserted after the power-up of the board. For more information to this case, see paragraph "ADDRESSES CONFIGURATION".



## OUTPUTS

### Digital interface:

The eight digital outputs are completely isolated, with either all control signals on the device, both with analogical outputs. Here below there are the diagrams of two typical connections of external device to WEB-ADIO-WiFi card: in the first case (Picture 2a), the card will manage directly some loads (with maximal current of 150mA). In the second case (Picture 2b), the card is connected to a high impedance device (i.e. the inputs of a PLC).

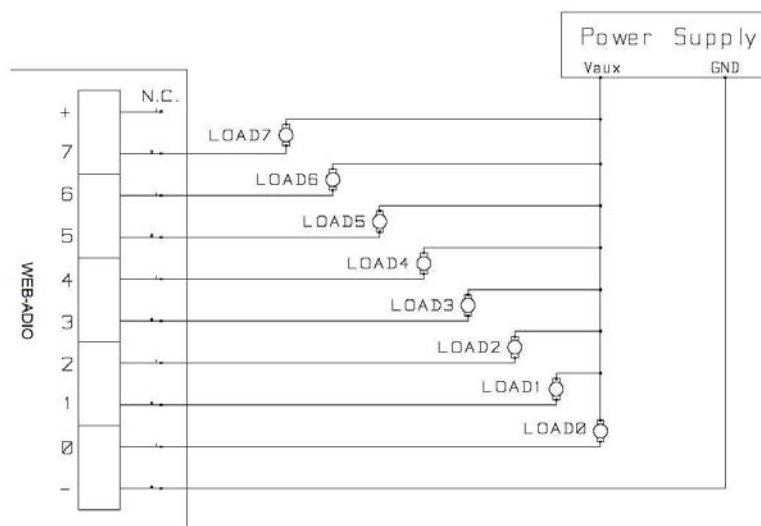

Picture 2a: diagram of the digital output connections: directly managing of loads

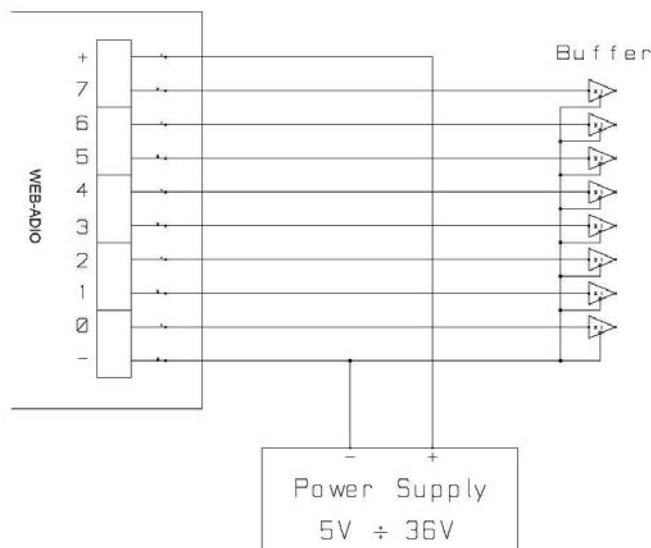

Picture 2b: diagram of the digital output connections: connection to a high impedance device

Output status is displayed by LEDs placed near every connector (LED from D5 to D12, showed in Picture 1).





### Analogical interface:

Each analogical output has a resolution of 10bits with a 0-10V voltage range and a low impedance driver and they are independent among them. As a negative voltage reference you must consider the ground output of the card. The maximum provided or absorbed output current is 25mA.

Here below there are the diagrams of three typical connections of analogical actuators to WEB-ADIO-WiFi card.

In the first case, see Picture 2c, the board drives directly the loads, with a maximum current of 25mA for each output.

In the second case, see Picture 2d, the actuators are powered from an external supply source: it is mandatory to connect together the negative voltage references. Where the actuators have an operating range greater than 10V and should use their whole dynamic, you must be placed between the outputs of the card and the actuators themselves a signal conditioning circuit control.

In the third case, see Picture 2e, the supply of the actuators is taken from the card. The maximum current driven by +10V connector, both analogical output side than analogical input side, is limited to 450mA.

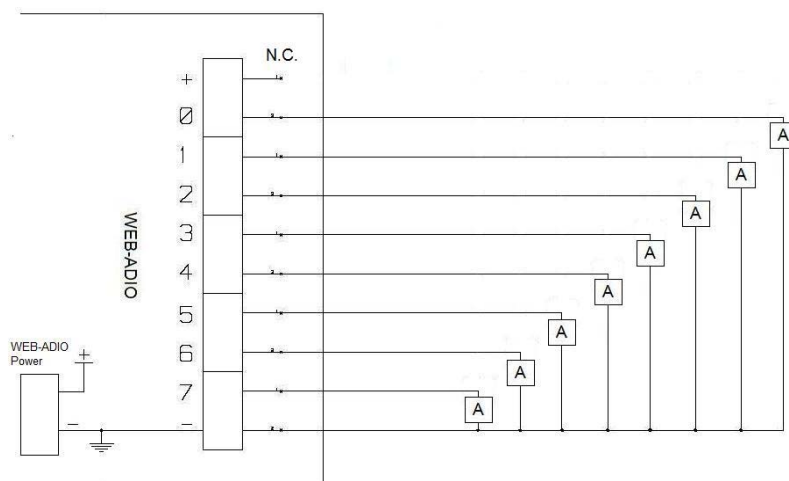

Picture 2c: diagram of the analogical output connections: managing of actuators with external power supply



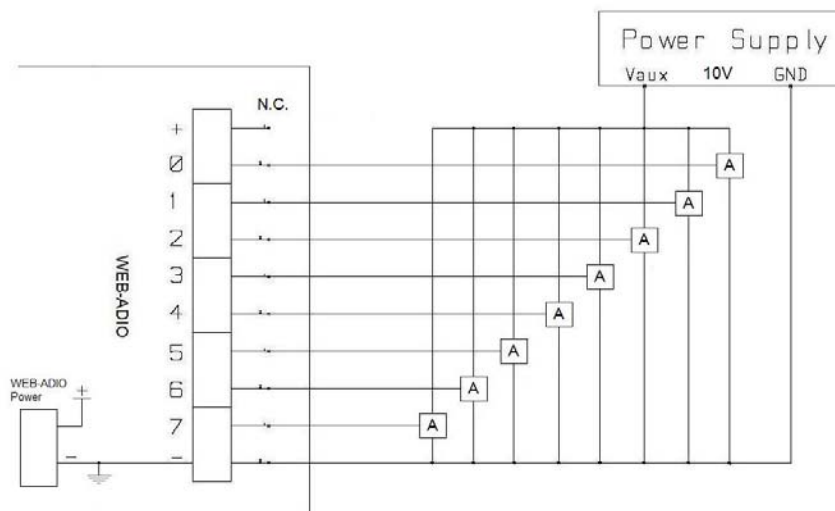

Picture 2d: diagram of the analogical output connections: managing of actuators with external power supply

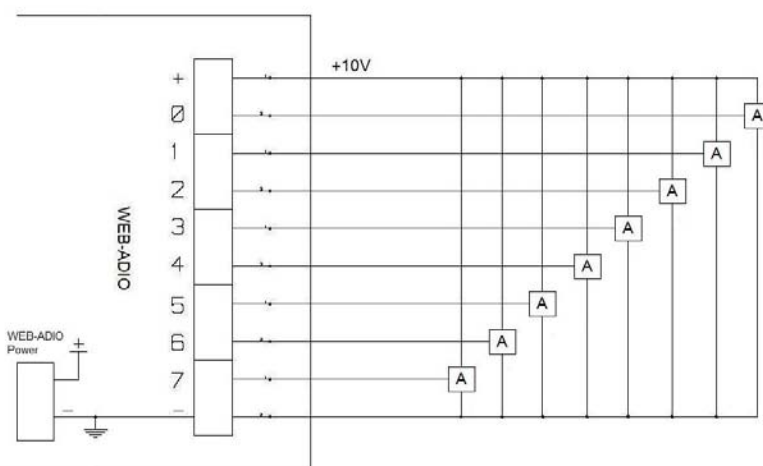

Picture 2e: diagram of the analogical output connections: managing of actuators with power taken from the card





## INPUTS

### Digital interface:

The eight digital inputs are completely isolated, with either all control signals on the device, both with analogical inputs.

We suggest to connect inputs following one of the two diagrams displayed below:

-Picture 3a: use this way in case inputs have to detect the pressure from a switch or an open collector output.

-Picture 3b: use this way in case inputs are directly controlled by a voltage.

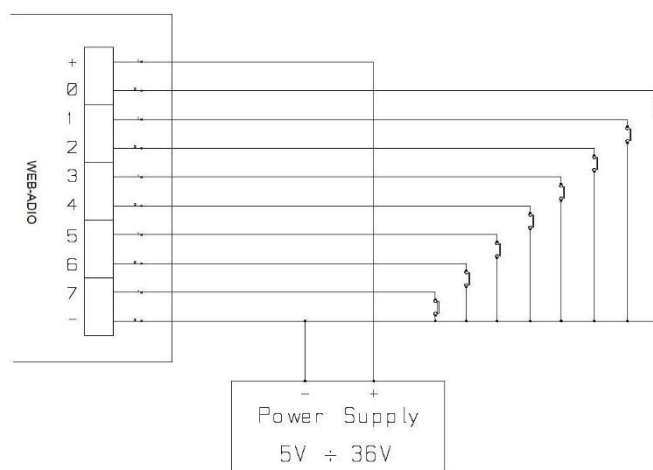

Picture 3a: diagram of input implementation: detection of the pressure from a switch or an open collector output

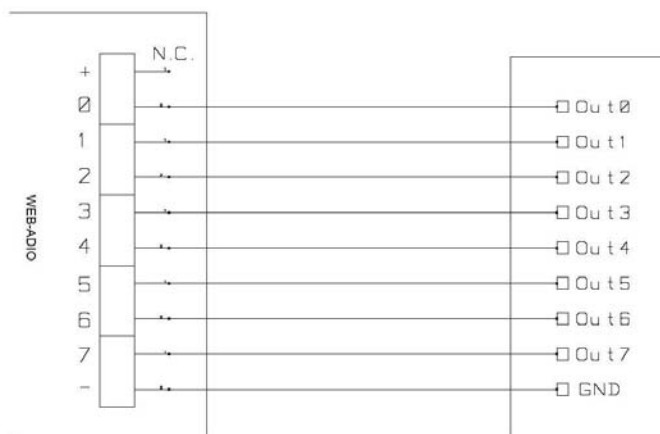

Picture 3b: diagram of input implementation: inputs directly controlled by a voltage

Input status is displayed by LEDs placed near every connector (LED form D13 to D20, showed in Picture 1).





Analogical interface:

All analogical inputs have an input impedance greater than  $1M\Omega$  and an hardware protection against overvoltage conditions. The resolution of the acquired signal is 10bits, in the 0-10V voltage range.

The following picture shows a typical connection among analogical inputs and linear transducers. The power supply is taken from the WEB-ADIO card. The maximum current driven by +10V connector, both analogical output side than analogical input side, is limited to 450mA.

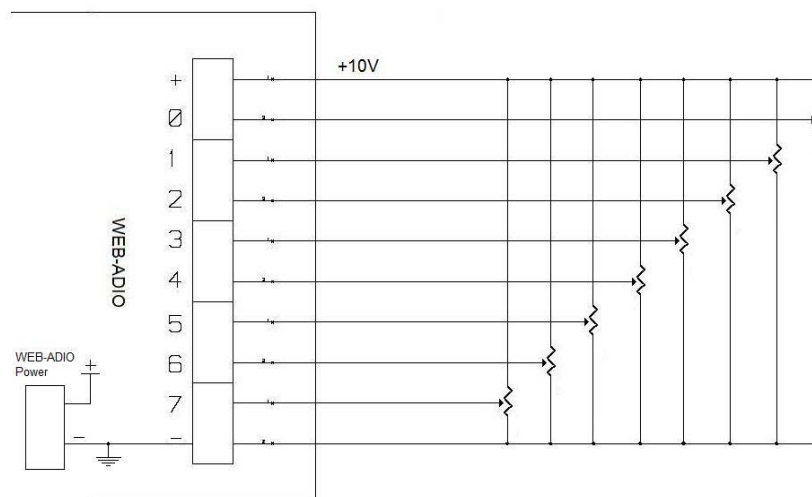

Picture 3b: diagram of input implementation: inputs directly controlled by a voltage

Alternatively, it is possible to take an external power supply: in this case it is mandatory to connect together the negative voltage references. A signal conditioning may be necessary to fit the 0-10V range.



## EXAMPLE OF USAGE

The follow example, in Picture 4, shows how you can connect the digital channels of the WEB-ADIO for manage an external load with line supply.

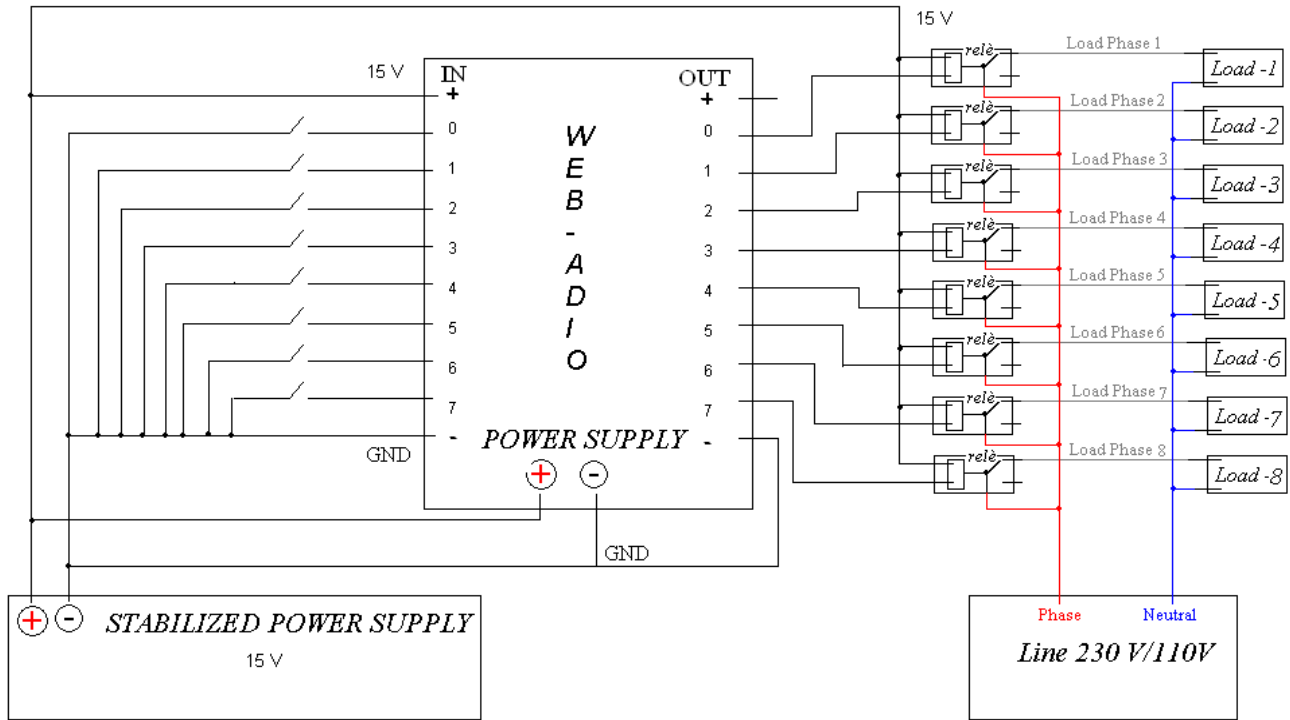

Picture 4: external load with line supply management

## FUNCTIONING MODES

The firmware of the board implements two different modes, as specified in the following table.

Mode	Descrizione
Operative	This is the normal mode. During this status, the control of the outputs and PLC and Timeout functions are fully available. The interaction with the board can be made by web browser, MIB browser, client telnet, or demo software.
Bootloader	Using this mode, the board waits for a firmware upgrade or a return to Operative mode. In this state all the outputs and PLC and Timeout function are disabled. The interaction with the board can only be made by a web browser.

The jumper J1 allows to select the physical interface for the network communication (cabled or wireless) before the power-up of the board, but only in Operative mode.

In Bootloader mode the card can use only the Ethernet interface (cabled) without regarding the status of jumper J1.

## LED STATUS

The LEDs D2, D3 and D4 indicate the status of the system.

In Operative mode the LED configuration is the following one:

LED D2	LED D3	LED D4	Status Description
Off	Off	Blinking	Device operative and configured with Ethernet interface. The network cable is not detected.
On	Off	Blinking	Device operative and configured with Ethernet interface. The network cable is detected.
Off	On	Blinking	Device operative and configured with wireless interface. No connection with any AP.
On	On	Blinking	Device operative and configured with wireless interface. Connected to the AP.
/	/	Static	System critical error. It is necessary to reboot the board.
Blinking	Blinking	/	Hardware resetting to factory settings or software TCP/IP address configuration
On	Blinking	/	telnet password modifying

In Bootloader mode the LEDs D2, D3 and D4 light up repetitively in sequence, until one remains in this state.

In Operative mode, with wireless interface active, if LED D4 crashes in a static status (on/off) more than 5 seconds means that a critical error occurred and the module needs to be rebooted.



## POWER SUPPLY

The board is equipped with a connector (see next Picture: the connector labeled as “VIN”) which allows to connect an external voltage supply to power the board: its value must be included from +15V<sub>DC</sub> up to +32V<sub>DC</sub>.

The voltage supply can be used also as “*Power Supply*”, as indicated in Picture 2b and 3a: by these way, the galvanic isolation of the board between I/O and control logic will be lost, so the GNDs must be connected together to avoid irreversible damage of the card.

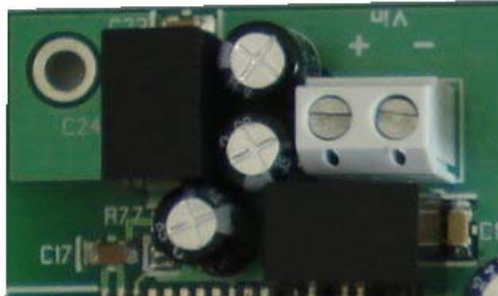

### **WARNING!**

The maximum supply voltage must not exceed +32V<sub>DC</sub>: in case of use of higher voltage the components of the board may damage irremediably.

## NETWORK INTERFACES – MAC ADDRESSES

The WEB-ADIO-WiFi board is equipped with two separate and independent physical network interfaces: a cabled interface (connector RJ45) and a wireless interface (WiFi module). These physical layer cannot work simultaneously (they are mutually exclusive) and their selection is made by jumper J1, during system start-up.

J1 status	Physical interface
Closed	Cabled
Open	Wireless

A univocal MAC Address is defined for each physical interface: one for the cabled one (Cabled MAC Address) and one for the wireless one (Wireless MAC Address).

The MAC Address shown on the http pages or requested from telnet or SNMP commands is relative to the active physical interface.

The Test Report of each board shows the MAC Address for both interfaces.

## ETHERNET MODULE

The physical layer of the Ethernet network protocol supports the 10Base-T standard and it is fully compliant with the 10/100/1000Base-T standard. The WEB-ADIO-WiFi can be connected to any commercial router or switch without problems.

The physical connection between the card and the network cable is made by the RJ45 connector, as shown in the following picture:

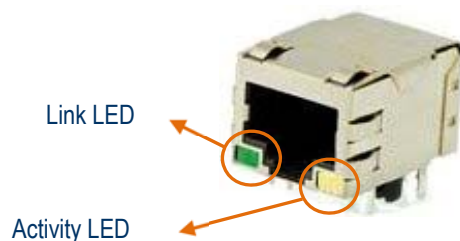

Picture 5: RJ45 Ethernet connector

The green LED (*Link LED*) indicates the detection of the Ethernet network, the yellow LED (*Activity LED*) is on during the communication packets Tx/Rx activity.

When the board runs with the wireless interface active, the LEDs of the RJ45 are always off, also if a network cable is plugged-in. To switch to the Ethernet interface, insert jumper J1 before power-up the board.

## WiFi MODULE

The WiFi module supports the IEEE 802.11b standard and is certified *Wi-Fi® compliant*. Thanks to this module is possible to control the board through an *Access Point* that supports this standard.

The WiFi module is available in two version: with integrated antenna (WEB-ADIO-WiFi), and with a miniaturized coaxial connector to allows to connect an external antenna (WEB-ADIO-WiFi-U.FL).

For application in which the card need to be enveloped into metallic box, we suggest to use the -U.FL module to avoid signal degradation due to the chassis.

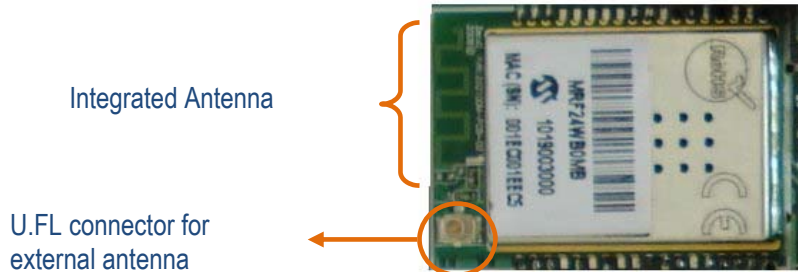

Picture 6: WiFi module

To establish a connection with an Access Point (AP) is necessary to know its SSID, authentication type and network key values.

The WiFi module accepts only Service Set Identifier (SSID) made by string from 2 to 32 of printable alphanumeric chars, without spaces.

The authentication method supported are described in the following table:

Authentication	Description
Open	The AP does not require any network key to connect
WEP	The AP requires a 5 chars key (WEP-40bit) or a 13 chars key (WEP-104bit) in ASCII or hexadecimal format.
WPA/WPA2 (Personal)	The AP requires a key made by 8 to 64 chars, in ASCII or hexadecimal format.

If the authentication type is WEP or WPA/WPA2, it is necessary to define a valid key, respect to the codifying method selected. Both SSID and key are case-sensitive.

The modifying of previous parameters is possible only from http pages: to improve a greater security the telnet service allows only their reading.

At every power-up the WiFi module calculate the security key before to connect with the AP: this process can require up to about 30 seconds, depends on authentication method implemented.

Some Access Points allow to join their network only to devices which MAC Address is included into a list of physical addresses allowed. If your AP has this option active, include the Wireless MAC Address of your card into the list: for more information refer to the user manual of your AP.

## CERTIFICATIONS AND REGIONAL DOMAINS

The WiFi module is able to work in the most common regional domains (Regulatory Domains), as defined by the *ANSI/IEEE Std 802.11, 1999 Edition* standard and subsequent integrations. The following table shows the list of the domain, with relative regions and channels:

Regulatory Agency	Regions	Channels
FCC	USA, Mexico	1-11
IC	Canada	1-11
ETSI	Europe	1-13
ARIB	Japan (only ch.14)	14
ARIB	Japan (ch.1-13)	1-13

The European normative include also Spain and France regions, that in the past became available only channels 10-11 and 10-13, respectively.

For South America regions must be adopted one of the indicated domains, relative to the regulations of the State where the system is: it is care of the user to comply with this.

The domain can be modified in the *http TCP/IP Configuration* page, as described in the *Server http* paragraph.

To keep valid certifications for own country it is mandatory to set correctly this field.

The following table shows the center band frequency associated to each channel:

Channel	Center Frequency (GHz)
1	2.412
2	2.417
3	2.422
4	2.427
5	2.432
6	2.437
7	2.442
8	2.447
9	2.452
10	2.457
11	2.462
12	2.467
13	2.472
14	2.484

The WiFi module has achieved the necessary approvals for radio emissions in the following regions:

- United States (FCC)
- Canada (IC)
- Europe (ETSI)
- Japan (ARIB)

Moreover, it has achieved the Wi-Fi® Alliance certification (WFA ID: WFA7150).

## NETWORK SERVICES

WEB-ADIO-WiFi board hosts a server for *http* service, a server for *telnet* service and a server for SNMP (Simple Network Management Protocol) service. Data transfer is based on a TCP/IP protocol: the protocol configuration parameters can be modified only from *http* service or the "TCP/IP ADDRESS CONFIGURATOR SOFTWARE" described in a later paragraph. To validate these changes a password named *http service password* is required.

Similarly, to access *telnet* service an authentication password named *telnet service password* is required.

Both passwords are case-sensitive alphanumerical strings with a valid length included between 1 and 8 characters. The default value for both is "ipses" and it can be modified only from the relevant service.

The SNMP service supports both V1 and V2c versions. The last one implements a community-based service access, which is an authentication access method. It is possible to set up to 3 different communities both for read and write operations.

The default communities are:

- Write Community ("private", "write", "public")
- Read Community ("public", "read", "").

Each specified community can be 8 chars maximum length; if none community is specified, the access to the pertinent service (read and/or write) is blocked.

## ADDRESSES CONFIGURATION

The following table shows the default configuration parameter of each board:

Parameter	Value
Hostname (NetBIOS)	WEBADIOWIFI
IP address	192.168.0.16
Subnet mask	255.255.255.0
Gateway address	192.168.0.4
Primary DNS	193.70.152.15
Secondary DNS	0.0.0.0
http password	ipses
telnet password	ipses
SSID (Access Point)	WEB-AP
Authentication	WEP-104bit
Key	www.ipses.com
Regulatory Domain	ETSI (Europe)
Startup status outputs	Digital: all OFF Analogical: all 0V

The addresses for Primary DNS server and Secondary DNS server must be modified according to the addresses assigned from the network's provider where you connect your board. For more information contact your network provider.

It is possible to restore factory parameters following this procedure:

- disconnect power supply from the board
- insert jumper J2 (see Picture 1 at page 8)
- connect power supply to the board

If the procedure is successfully completed, LEDs D2 and D3 will flash alternatively for about 3 seconds. At this point it will be possible to remove jumper J2 from the board.

If TCP/IP parameters of the network are not compatible with default board parameters, or if the IP address is already assigned to another device, you can reconfigure them choosing between the following two procedures:

### ❖ Manual configuration procedure

- connect the board locally and directly to a PC equipped with a network card (without connect it to any network).

- verify that in the *Property* items under *Local Network Connection Status (LAN)* window located in *Control Panel » Network Connection Properties* path the IP address of your PC is 192.168.0.1 and their Subnet Mask is 255.255.255.0. Otherwise set these values in their respective fields.
  - power on the board and access to *http* service typing in the URL browser the current board address (by default <http://192.168.0.16/>).
  - go to the *TCP/IP Configuration* page, then set the new parameters and save them. Verify Save & Reboot operation works successfully.
  - install the card in the network and access it with new parameters.
- ❖ **Software configuration procedure**
- with the board already powered on, insert the jumper J2.
  - Run the address configurator software “WEB-ADIO-WiFi Address Configurator.exe” included in the installer CD provided with the board, and follow the steps described in the paragraph “TCP/IP ADDRESS CONFIGURATION SOFTWARE”.
  - at the end of the configuration, remove jumper J2.

**IMPORTANT:** do not disconnect the power supply during the address configuration procedure: a supply reset restore factory parameters.

## http SERVER

The *http* server implemented on the board allows to manage up to 5 simultaneous sessions.

To access the server, open a web browser and type the board IP address <http://192.168.0.16/> in the URL field: you will be redirect to the main page, *index.htm*, as shown in Picture 7.

The implemented server was tested and was resulted fully compliant with the following browser:

- Microsoft Internet Explorer 8.0.7600.16385
- Mozilla Firefox 3.6.12
- Google Chrome 7.0.517.44
- Apple Safari 5.0.3 (7533.19.4)

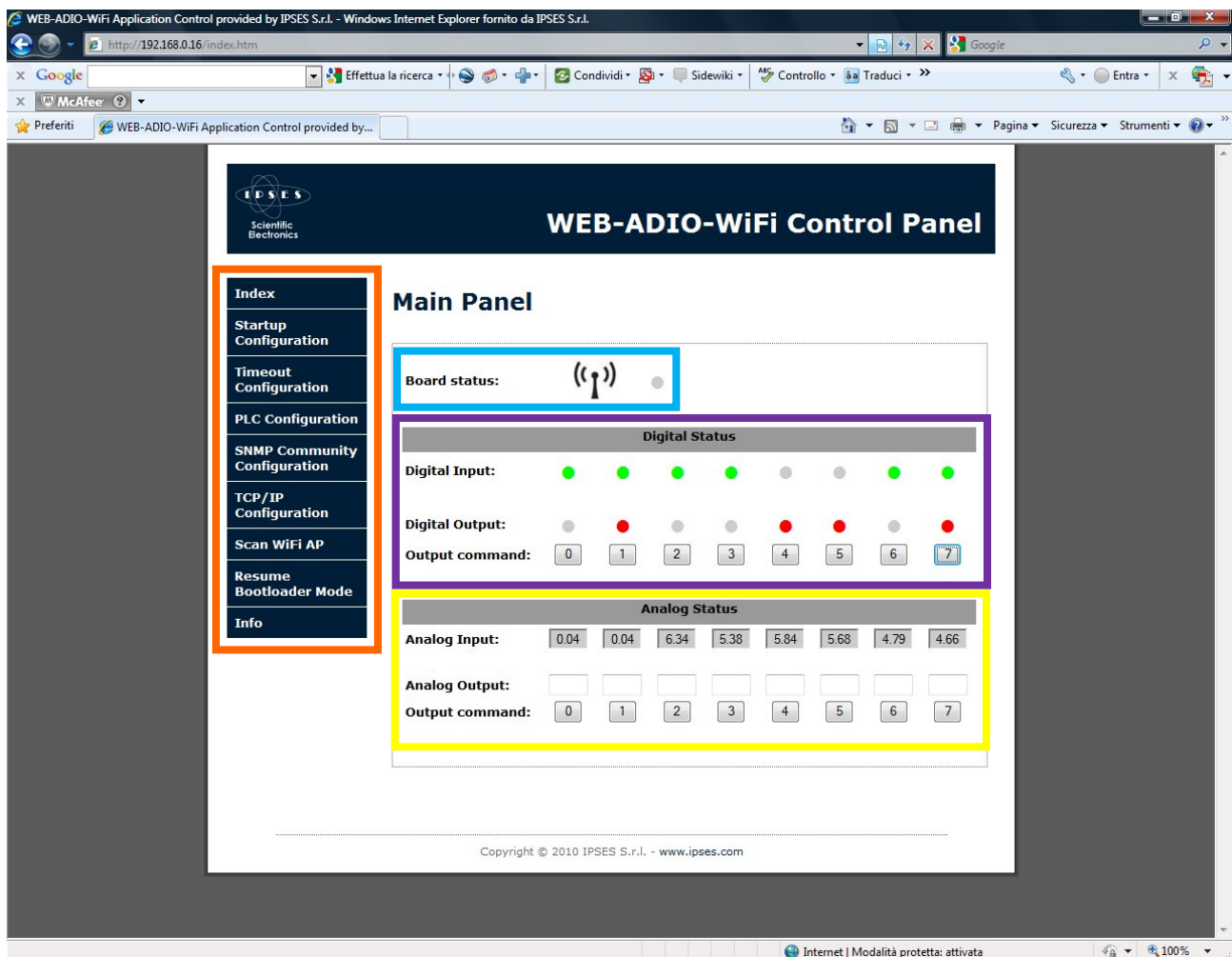

Picture 7: *http* server index page.

On the left side of the WEB-ADIO-WiFi control panel there is the menu (surrounded in orange in Picture 7) which allows to access the pages implemented on the *http* server.

*Board status* (surrounded in blue) shows the network interface active on the board by an image (a stylized antenna or a cable), and D4 status LED mounted on the card.

The section related to the I/O digital channel is surrounded in violet. *Digital Input* and *Digital Output* fields, report respectively the current status of each inputs and outputs of the digital channel. *Output command* buttons, labeled from 0 to 7, drive the outputs: each button pressure set or reset the relative digital output.

The filling colors used in the *http* page are correspondent to the LEDs mounted on the card.

The section related to the I/O analogical channel is surrounded in yellow. The *Analog Input* indicators show the read voltage from the corresponding input, measured in Volts. To set-up the outputs you must insert a valid voltage value, in the 0-10V range, in the *Analog Output* controls and click the associated *Output Command* button.

If the communication is lost the current page shows the following error message: “*Connection to WEB-ADIO-WiFi board was lost*”.

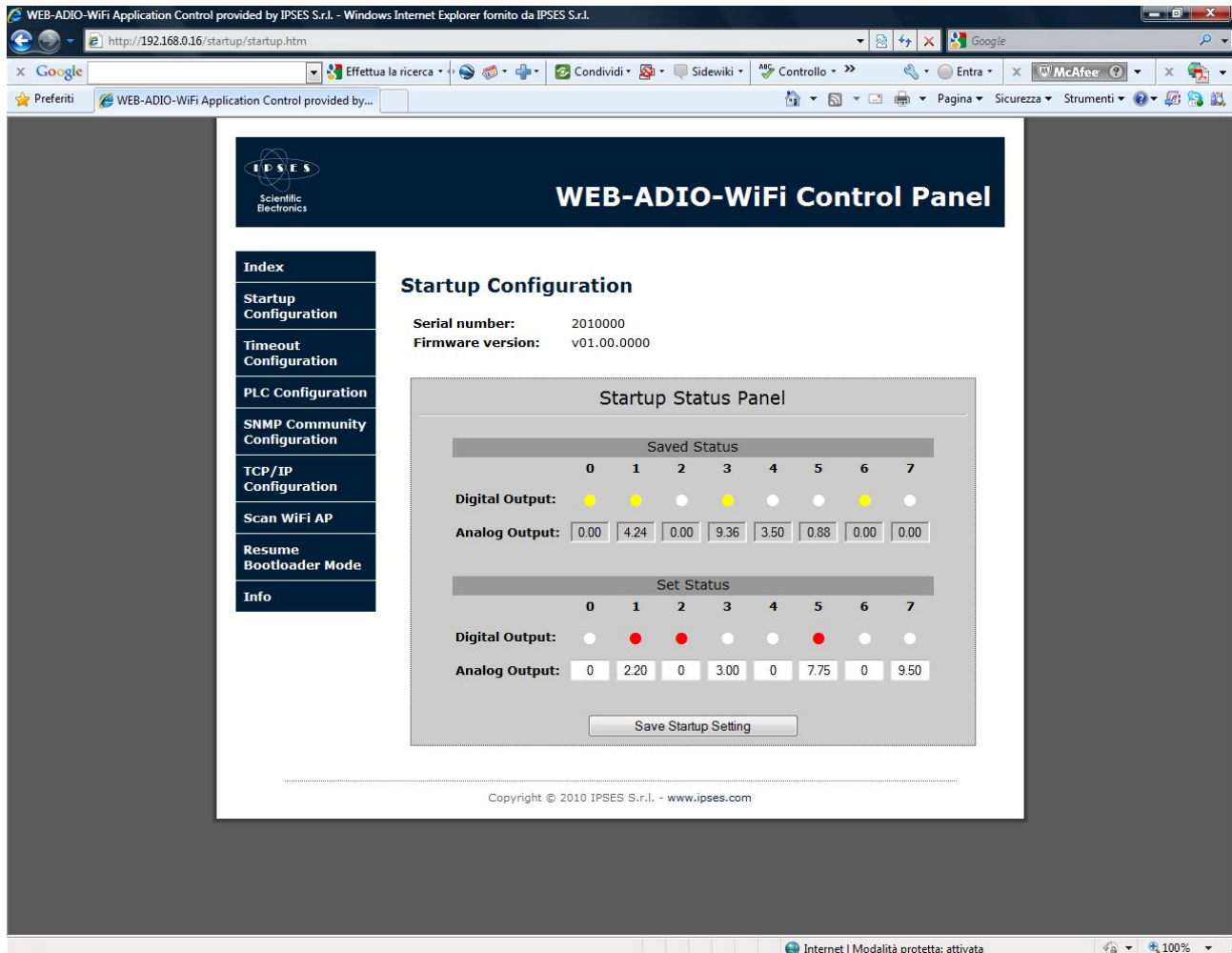

Picture 8: Startup configuration page.

*Startup Configuration* page, shown above in Picture 8, allows to read identification board parameters (like *Serial Number* and *Firmware Version*), and to set the startup digital and analogical outputs status through the *Startup Status Panel* form. *Saved status* field displays the actual startup configuration stored in memory: digital outputs status is shown by yellow LEDs, while analogical outputs status is reported in the *Analog Output* indicators.

The *Set Status* field allows to set up a new startup configuration: for digital outputs by clicking on LEDs and for analogical outputs by typing a valid value, included in the 0-10V range, into the *Analog Output* control boxes.



The new startup configuration will be stored only after the pressure of *Save Startup Settings* button.

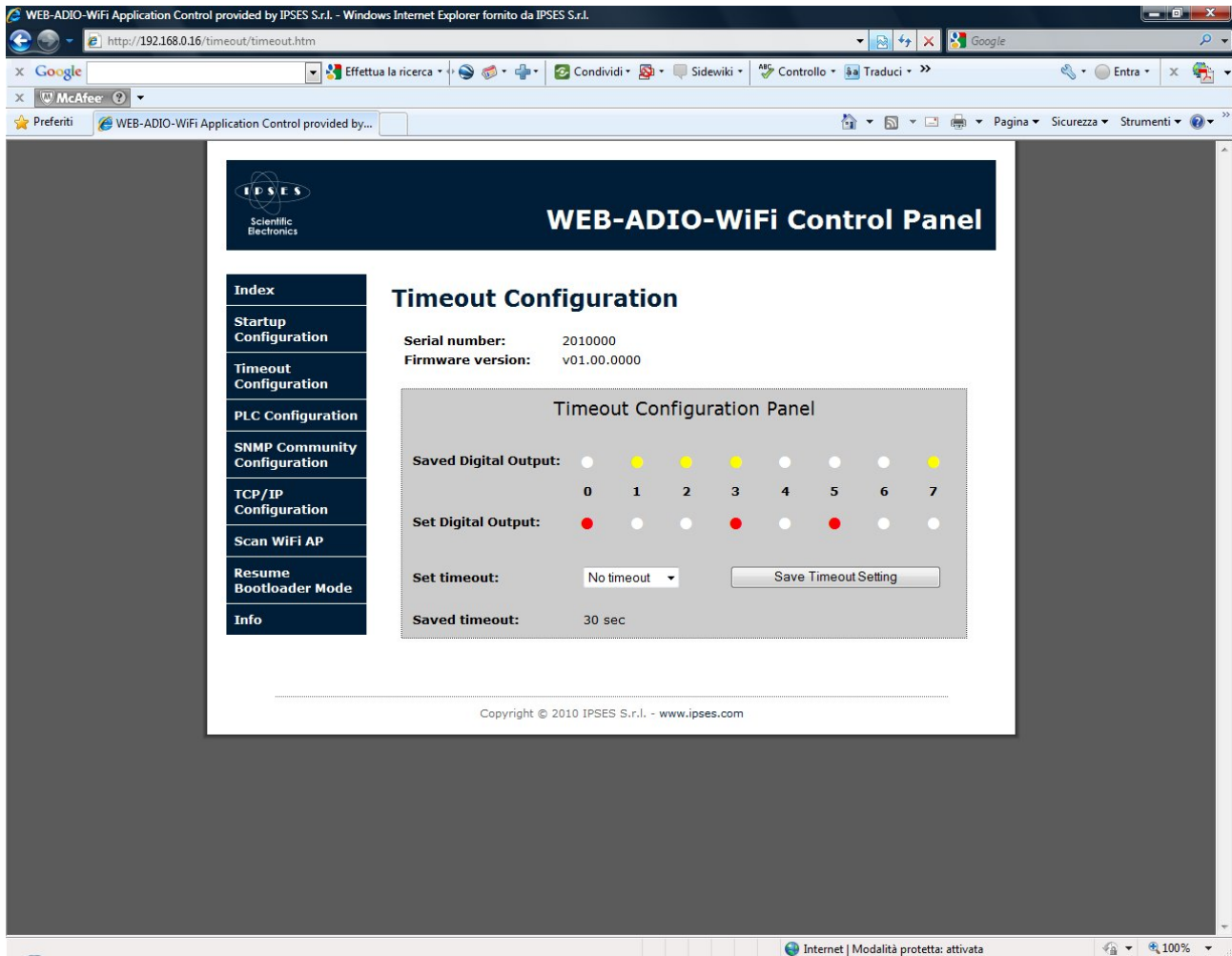

Picture 9: Timeout parameters configuration page.

*Timeout Configuration* page, shown in Picture 9, allows to read and to set the parameters of the Timeout function, that acts only on the digital outputs. *Saved status* field display the status of the digital outputs if the *Saved timeout* field time elapses with no commands or requests received by the board.

Clicking on LEDs of *Set status* field it is possible to set new digital outputs configuration, while *Set timeout* field allows to select the new timeout time among the following items: "No timeout", "5sec", "10sec", "30sec", "1min", "5min", "10min", "30min", "1hour". "No timeout" item disables the Timeout function on the board. The *Save Timeout Setting* button stores the new settings on the memory of the board.

The Timeout function has priority over PLC function, described next. When the Timeout function occurs, the outputs will be sets as configured and remain in this status, while any active PLC logic will be temporarily disabled, until the board will not receive a new command or request.

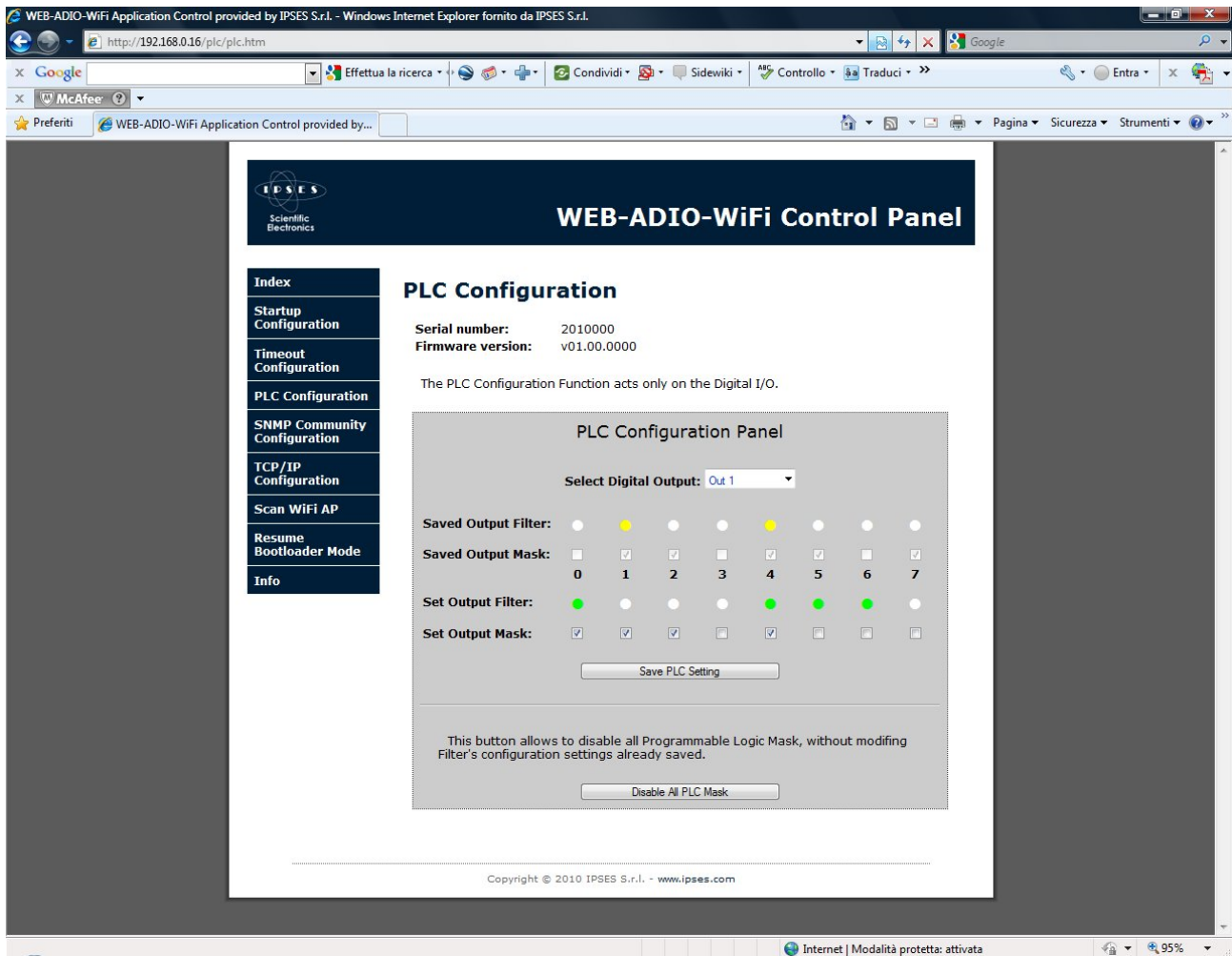

Picture 10: Programmable Logic Configuration (PLC) page.

*PLC Configuration* page, shown in Picture 10, allows to manage each digital output in function of the customizable status of the digital inputs (from 0 to 7). For example, as shown in picture above, user can set the output n. 1 to switch on when digital inputs 1-4 are high and digital inputs 2-5-7 are low (other inputs are *don't care*).

To do this, select the desired output through the *Select Digital Output* ring in the upper part of the PLC configuration panel. In the same panel, the *Saved Output Mask* field and *Saved Output Filter* field show the stored values for that output. Clicking on *Set Output Mask* checkbox field and *Set Output Filter* LED field it is possible to configure new mask and filter settings. If an input is not masked, it will be not considered from the logic function, independently of its filter status selection. To make the new values operative, click on *Save PLC Setting*.

When the PLC function is enabled on an output, the output status will be set according the customizable input status. For this reason, it will be not possible to manually set that output until the PLC function is enable. To do this, user needs to disable the PLC function.

To disable the PLC function on an output, all inputs must be not masked: the relative item in the *Select Digital Output* ring will became grey, otherwise it will remain blue.

The *Disable All PLC Mask* button in the lower part of the PLC panel allows to reset and store the mask of each output, without modifying the filter settings.

The *Timeout* function (previously described and shown in Picture 7) has priority over PLC function: if timeout occurs, all PLC enabled functions are temporarily disabled until the board will receive a new command or request.

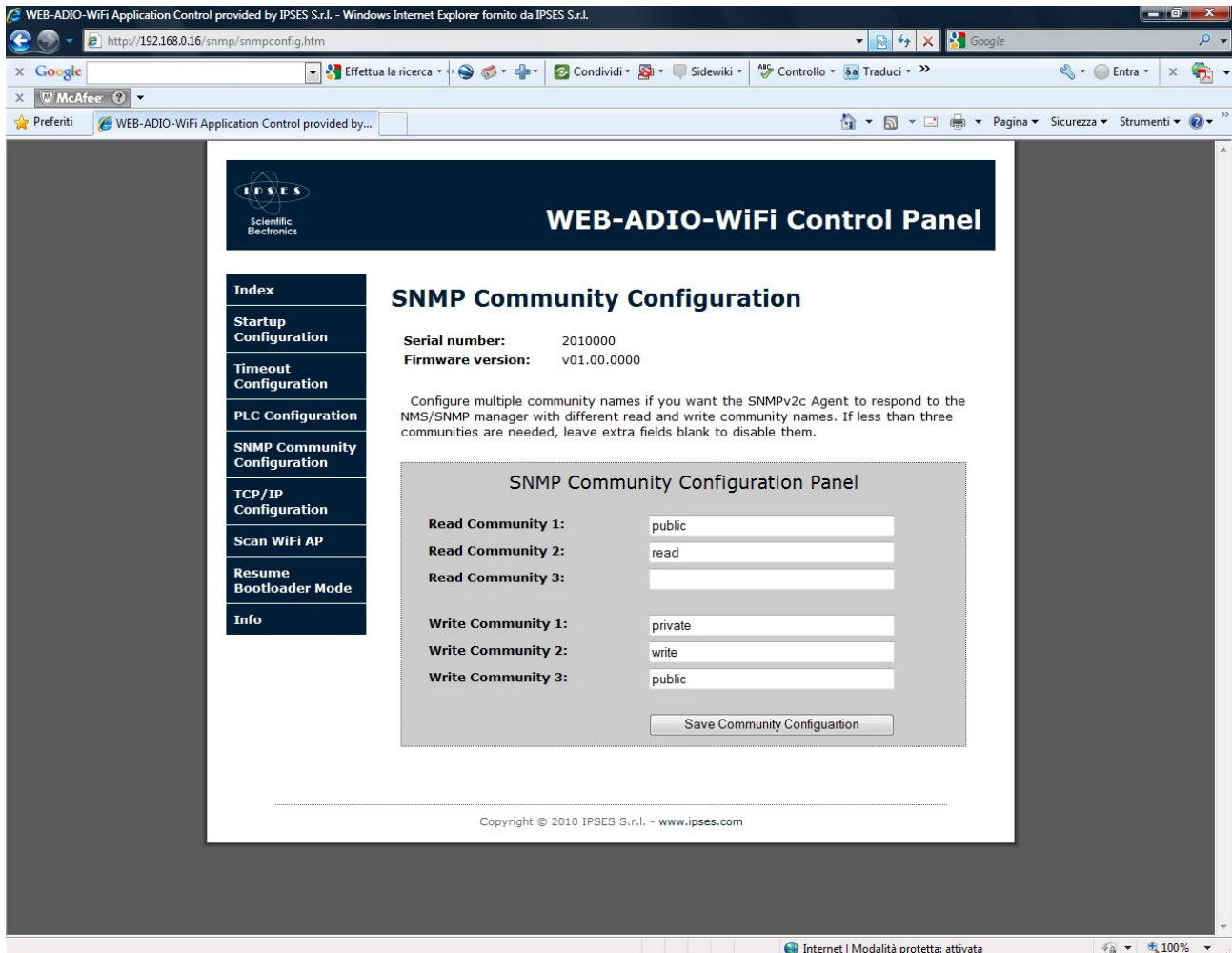

Picture 11: SNMP Community configuration page.

The *SNMP Community Configuration* page, shown in Picture 11, allows to set the read and write communities for the SNMP server V2c.

Each community can be a case-sensitive alphanumeric string, with a maximum length of 8 characters. If you do not want to set one or more communities, leave the extra fields blank.

If all fields are left blank, it will be impossible to access to SNMP server.

The queries run in the MIB browser can be evaluated from the SNMP server only if the community with which the request is generated is included in the configuration list.

The button *Save Community Configuration* stores the settings on the board.

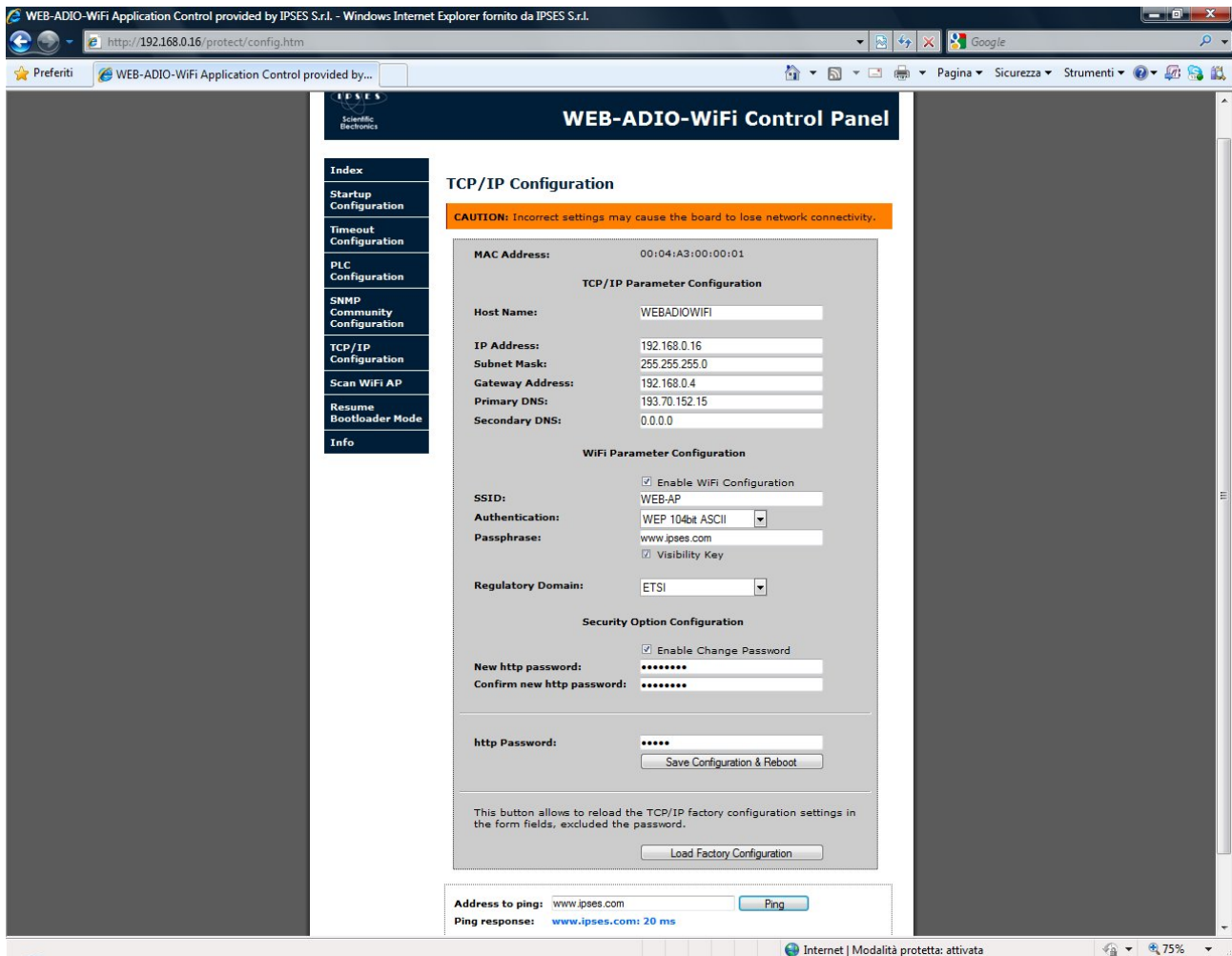

Picture 12: TCP/IP protocol, AP access parameters and *http* password configuration.

*TCP/IP Configuration* page, shown in Picture 12, allows to modify some TCP/IP protocol parameters, the configuration parameters for the WiFi Access Point and the *http* password of the board.

The *hostname* (for NetBIOS protocol) can be maximum 16 alphanumeric case-insensitive characters length.

The WiFi settings are not saved by default: to enable this option click the *Enable WiFi Configuration* field. Now, these fields are enabled and they can be modified.

The *SSID* field accepts a string from 2 and up to 32 alphanumeric chars, without spaces.

The *Authentication* field allows to select the kind of protection implemented by the AP and the format of the key to insert into the *Key/Passphrase* field, as described in the following table:

Authentication	Key	Description
Open	None	The AP does not required a key
WEP 40bit hex	WEP-40bit	It is required a key of 5 pairs of chars (byte) in an hexadecimal format (i.e.: "6970736573")
WEP 40bit ASCII	WEP-40bit	It is required a key of 5 alphanumeric chars (i.e.: "ipses")
WEP 104bit hex	WEP-104bit	It is required a key of 13 pairs of chars (byte) in an hexadecimal format (i.e.: "7777772E69707365732E636F6D")

WEP 104bit ASCII	WEP-104bit	It is required a key of 13 alphanumeric chars (i.e.: "www.ipses.com")
WPA Key	WPA-Personal	It is required a key between 8 and 64 pairs of chars (byte) in an hexadecimal format (i.e.: "69707365732D574542")
WPA Passphrase	WPA-Personal	It is required a key between 8 and 64 alphanumeric chars (i.e.: "ipses-WEB")
WPA2 Key	WPA2-Personal	It is required a key between 8 and 64 pairs of chars (byte) in an hexadecimal format (i.e.: "69707365732D574542")
WPA2 Passphrase	WPA2-Personal	It is required a key between 8 and 64 alphanumeric chars (i.e.: "ipses-WEB")

The *Visibility Key* checkbox allows to hidden the network key: if the option is enabled (factory condition) the *Key/Passphrase* field shows the current key stored on the board when the http page is loaded; otherwise this field will be highlighted in yellow, to indicate the invalid value. It is necessary to edit a valid key.

This option influence also the *telnet* service: if the visibility is hidden, the message "*Hidden Key*" will be printed if authentication is not *Open*.

The *Regulatory Domain* field allows to select the regional domain, regarding to *ANSI/IEEE Std. 802.11, 1999 Edition* and following integration, as described in the *WiFi Module* paragraph. The domain selected will be active only by the next power-up of the board.

To maintain the certification of own country, it is mandatory to set correctly this field.

To modify and save these parameters, it is necessary to insert a valid *http* password then press the *Save Configurations & Reboot* button. If the password is invalid or the data processing fails, the set parameters will not be saved and you will be redirect to an error page. To come back, click on the appropriate link.

To modify the http password, enable the *Enable Change Password* option, then insert a new valid password in the *New Password* field and repeat it in the *Confirm New Password* field. If the passwords inserted are different, a message error will be shown.

The *Load Factory Configuration* button allows to restore factory parameters, excepted for the *http* password that will not be modified.

At the end of the page is available the Ping function which allows to verify the connection between card and inserted address. If the communication is lost, the ping section shows the following error message: "*Connection to WEB-ADIO-WiFi board was lost*".

Warning: if the saved parameters are invalid or they could not be resolved in your network, you will lose the communication. To restore all default parameters, follow the procedure described in "ADDRESSES CONFIGURATION" paragraph.

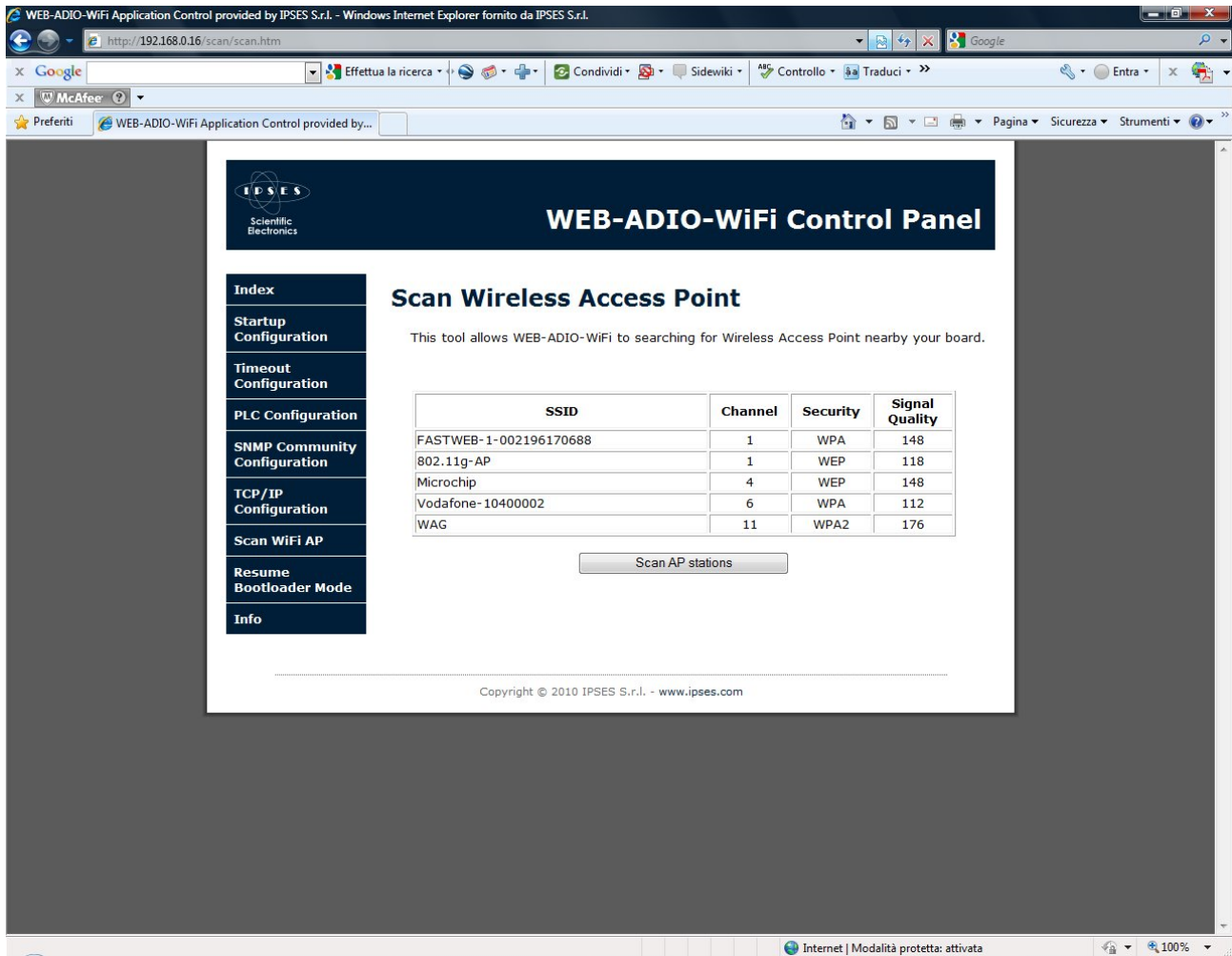

Picture 13: Scan Wireless Access Point page, with an example of founded networks.

The utility in the *Scan Wireless Access Point* page allows the WiFi module to search for wireless network in the surrounding area. The search result will be shown in a dedicated table.

The *Scan AP stations* button starts the wireless networks searching process: during this phase the button will be disabled and it will be enabled at the end of the search. The searching time can take some seconds.

The parameters listed in the result table are:

- *SSID:* Access Point *Service Set Identifier*
- *Channel:* communication channel in the available band (regarding the *Regulatory Domain*)
- *Security:* authentication implemented by the Access Point
- *Signal Quality:* indication of the wireless signal quality detected by the WiFi module.

The indication of the signal quality is mapped with a scale of values in the 0-255 range: greater is the value, better is the quality of wireless signal.

Attention: this *Scan* function is available only when the board runs with wireless interface active.

In case of the card runs with cabled interface, the searching button will be disabled and the page shows a warning message: "Scan tool is available only while the board uses the wireless interface."

The scan process check for the presence of the Access Points on each channel thanks to the transmitted SSID detection. If an AP does not send its SSID, it cannot be detected.

It is possible that during the detection temporal window of a channel, the AP, also if present, does not transmit its SSID in time (especially if the broadcasting time is high): this can compromise the AP detection. We recommend to perform the scan procedure several times, to ensure to identify all visible WiFi networks.

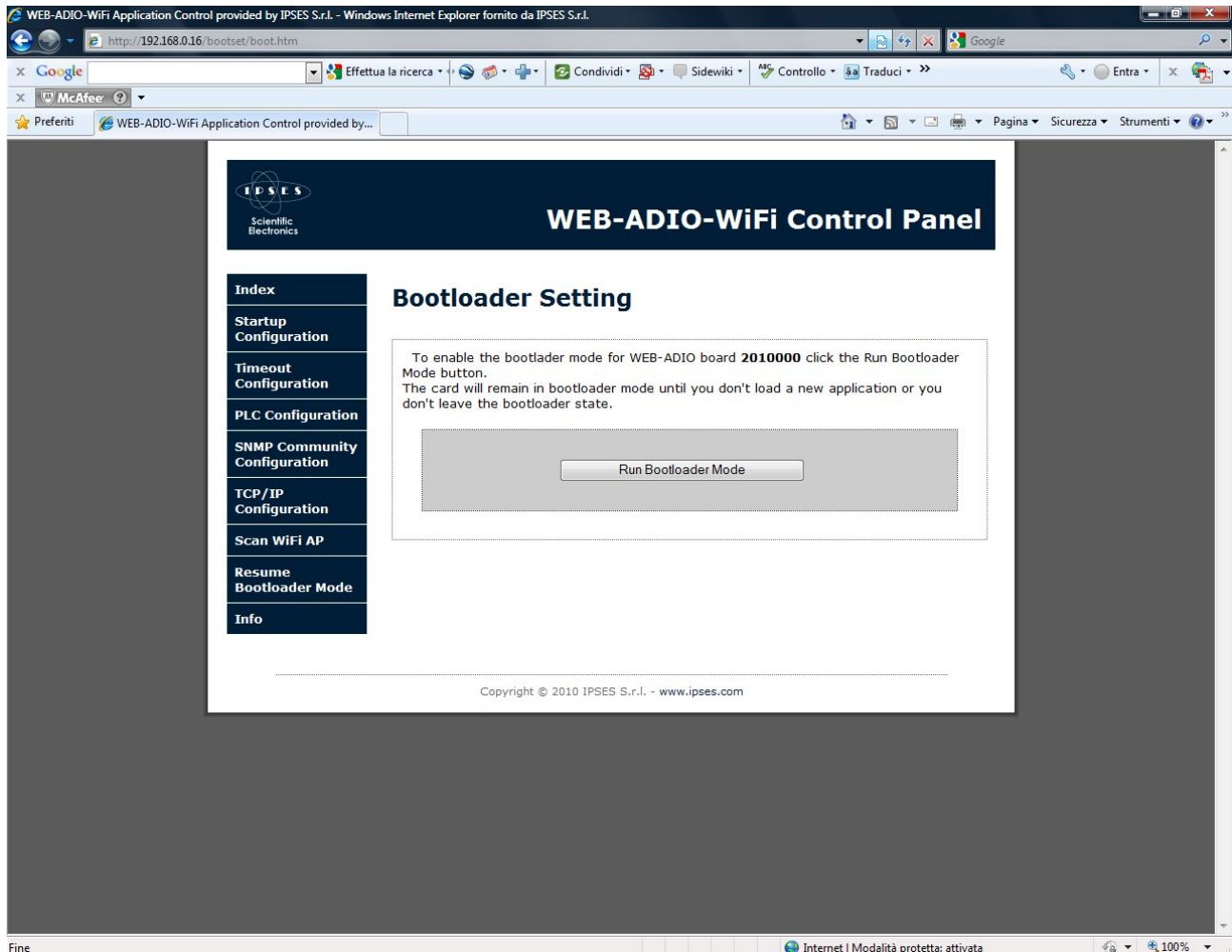

Picture 14: Bootloader mode access page.

The *Bootloader Setting* page, shown in Picture 14, allows to run the bootloader mode on the board for a firmware upgrade. Clicking on the *Run Bootloader Mode* button you will be redirect to the following network address: <http://current-ip/bootloader> (where *current-IP* is the current IP address of the board, i.e. 192.168.0.16).

Picture 15 shows the only page reachable in Bootloader mode: the board runs only with Ethernet interface, regardless the jumper J1 status.

Until the board remain in this state, the SNMP server and the telnet server are unreachable, while all the outputs and *PLC* and *Timeout* function are disabled.

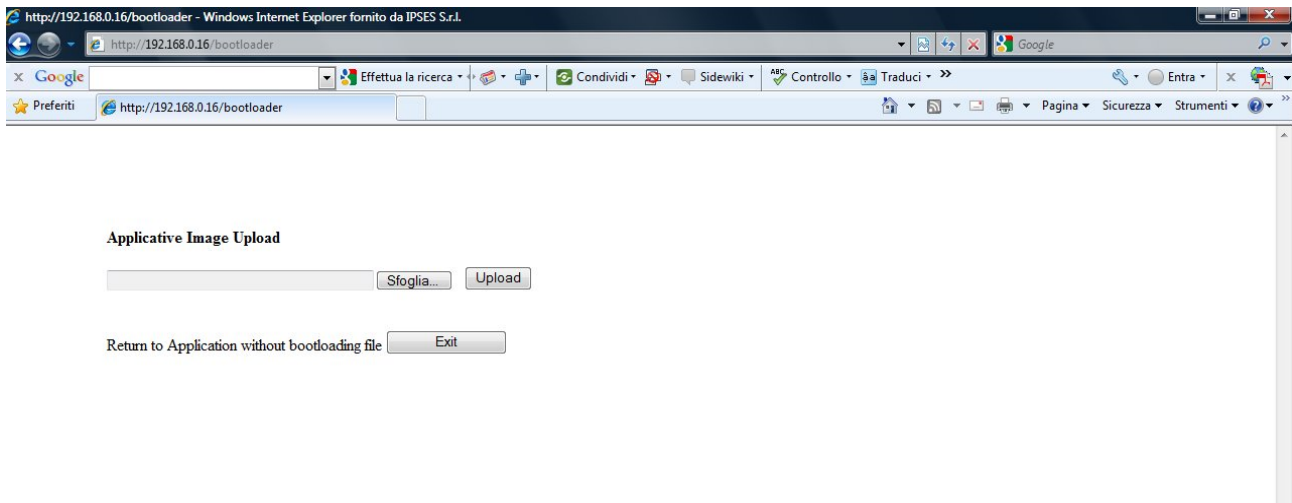

Picture 15: Firmware upgrade page.

The *Search* button allows to select the .bin file with the new firmware, and the *Upload* button starts the installation process. If the upgrade is completed successfully, the board will automatically return in Operative mode and you will be redirect to *index* page.

To exit the Bootloader mode with no upgrade, click the *Exit* button.



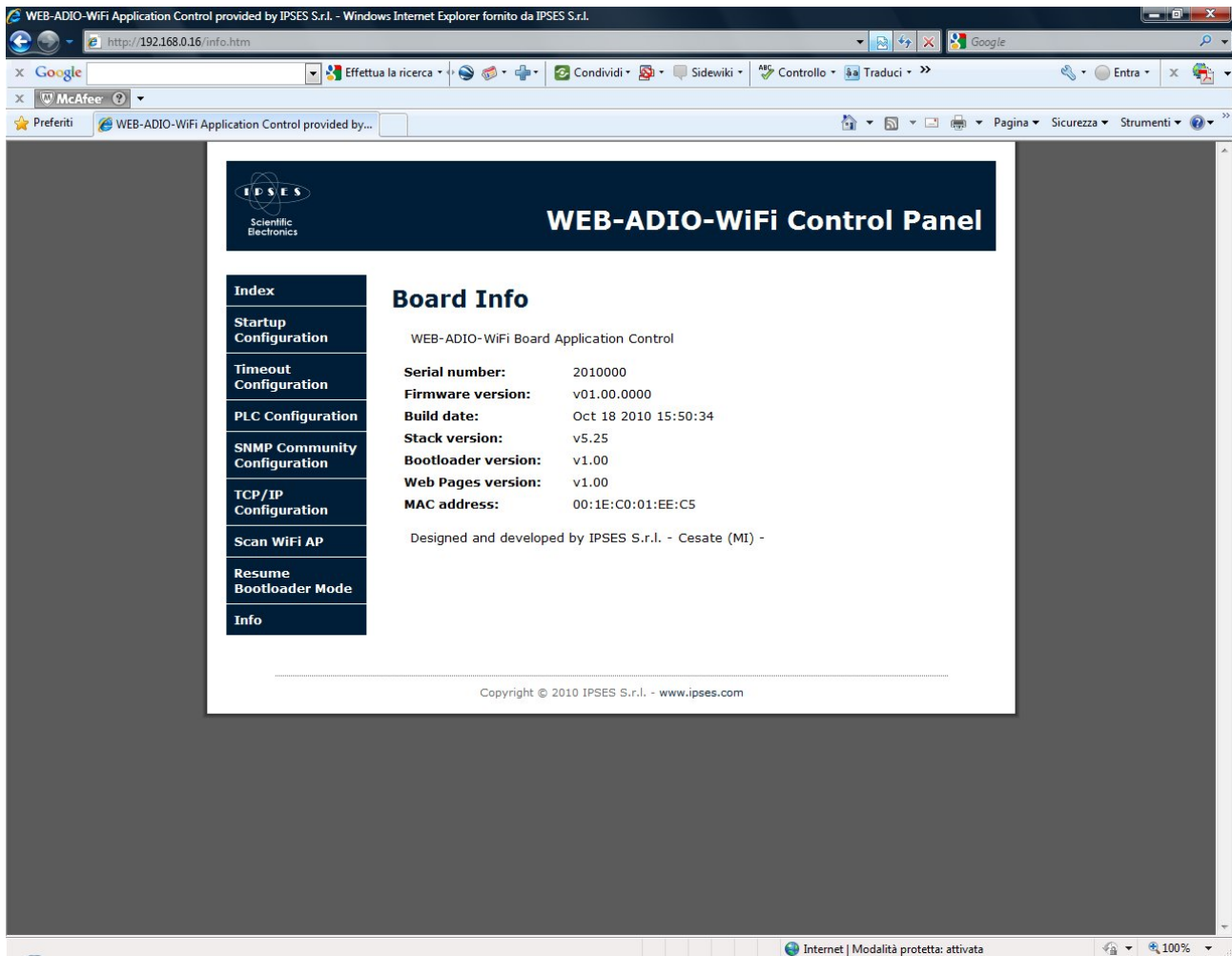

Picture 16: Firmware version information page.

The *Board Info* page, shown in Picture 16, lists the main information concerning firmware version running on the board. Note that the MAC Address shown in this page is referred to the physical network interface active.

## I/O MANAGEMENT THROUGH http

The WEB-ADIO-WiFi board can be interfaced to embedded system where should be useful to command or to read the digital and analogical I/O status through *http* protocol, without perform a parsing of the previous described web pages.

The I/O reading, both digital than analogical, can be performed by edit in the URL the following address: <http://current-ip/file>, where **current-ip** is the board address (i.e.: 192.168.0.16) and **file** is one among the following files:

- `getdo.cgi` read the digital output status in hexadecimal format (MSB is Out7 and LSB is Out0).
- `getdi.cgi` read the digital input status in hexadecimal format (MSB is In7 and LSB is In0).

- getao.cgi read a series of eight strings, divided by \r char, each of them indicate the value of correspondent analogical output, start from Out0.
- getai.cgi read a series of eight strings, divided by \r char, each of them indicate the value of correspondent analogical input, start from In0.

To set a digital output edit in the URL the following address: <http://current-ip/digbutton.cgi?dbtn=x>, where **x** is referred to the digital output desired (0-7).

This command acts on the selected output by performing a change of its current status: it does not allows to select the logical level (high or low), but only to perform a toggle, unless the output is not tied to a logical level by the PLC function active.

To set an analogical output value edit in the URL the following address: <http://current-ip/anbutton.cgi?abtn=o:x;y>; where **x** is referred to the analogical output (0-7), and **y** is the value , in Volts, with the *vv.vv* format (i.e.: 10.00 or 2.53).

The http page shown by the board as response to these commands is a blank page: the user must take care to digit correctly the URL addresses and the parameters.

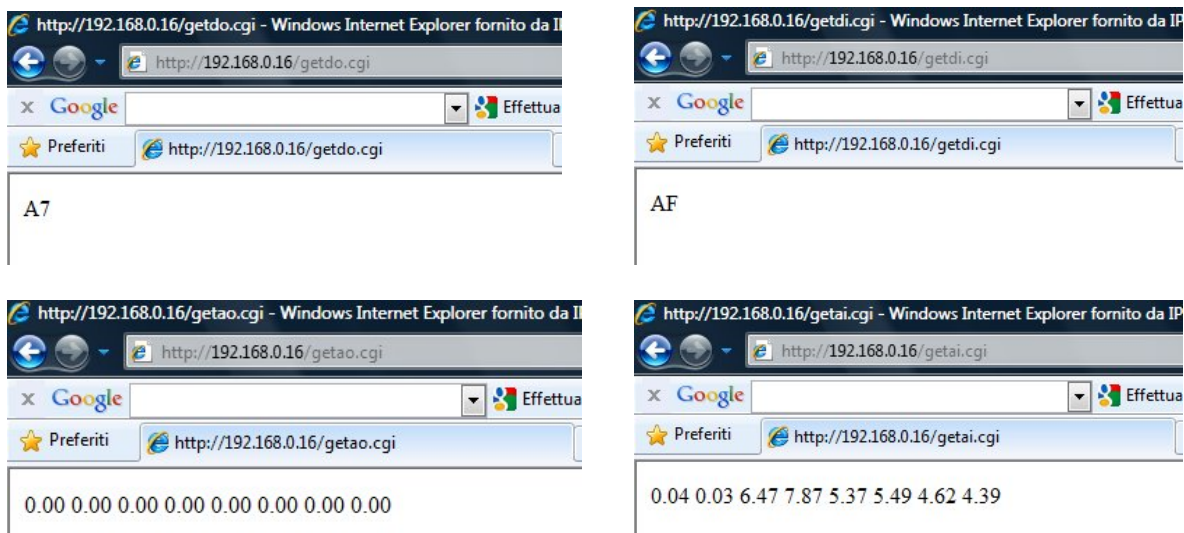

Picture 17: Example of answers to getdo.cgi, getdi.cgi, getao.cgi and getai.cgi files.

## telnet SERVER

To connect to the *telnet* server implemented on the board it is enough a telnet client program (as the client installed in your operative system or the *hyperterminal*).

The configuration parameters of the client must be:

- telnet communication port: 23;
- echo: on (if you want to see typed characters);
- termination characters: <CR LF> (\r\n).

Picture 18 shows the initial snapshot: to access the server, insert the *telnet* password, then press "Enter".

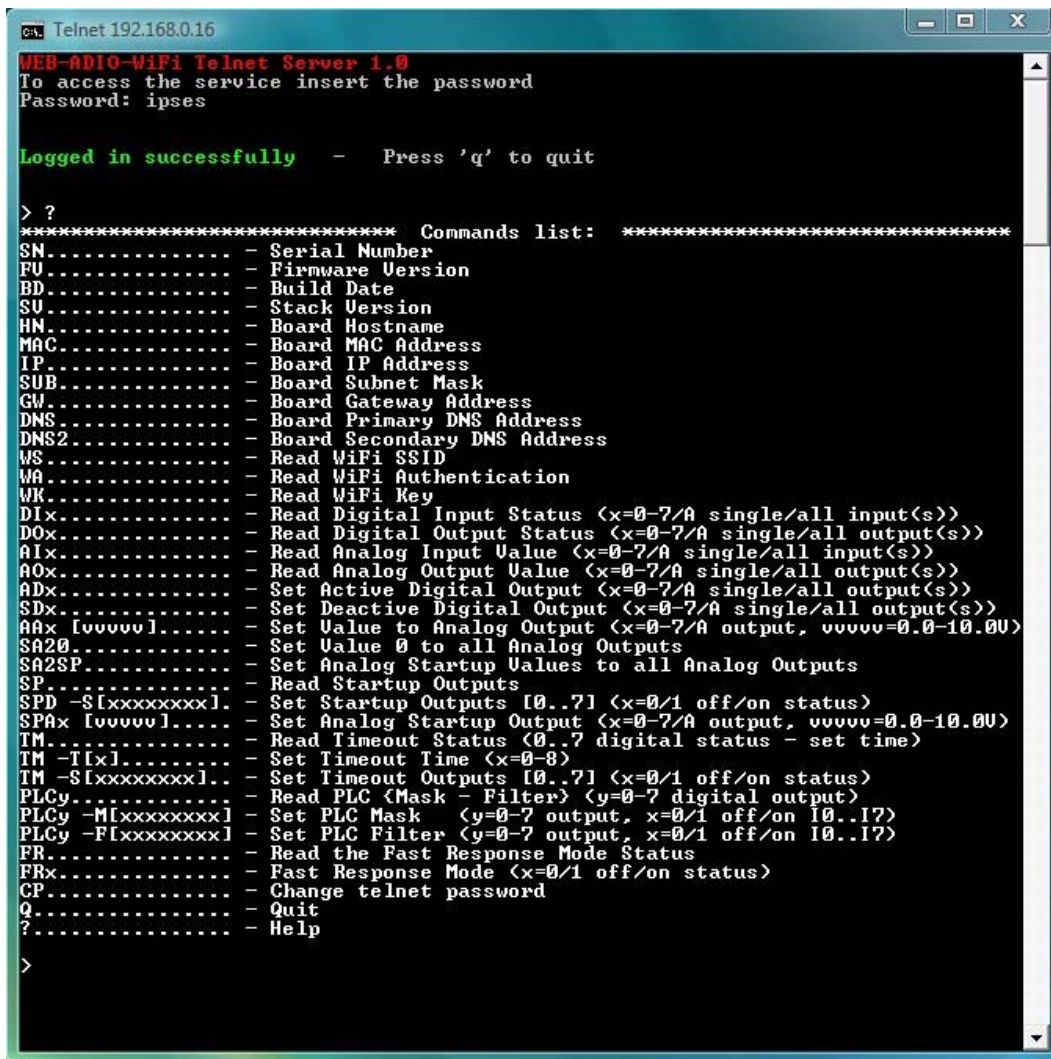

```

c:\ Telnet 192.168.0.16
WEB-ADIO-WiFi Telnet Server 1.0
To access the service insert the password
Password: ipses

Logged in successfully - Press 'q' to quit

> ?
***** Commands list: *****
SN..... - Serial Number
FU..... - Firmware Version
BD..... - Build Date
SU..... - Stack Version
HN..... - Board Hostname
MAC..... - Board MAC Address
IP..... - Board IP Address
SUB..... - Board Subnet Mask
GW..... - Board Gateway Address
DNS..... - Board Primary DNS Address
DNS2..... - Board Secondary DNS Address
WS..... - Read WiFi SSID
WA..... - Read WiFi Authentication
WK..... - Read WiFi Key
DIx..... - Read Digital Input Status (x=0-7/A single/all input(s))
DOx..... - Read Digital Output Status (x=0-7/A single/all output(s))
AIx..... - Read Analog Input Value (x=0-7/A single/all input(s))
AOx..... - Read Analog Output Value (x=0-7/A single/all output(s))
ADx..... - Set Active Digital Output (x=0-7/A single/all output(s))
SDx..... - Set Deactive Digital Output (x=0-7/A single/all output(s))
AAx [vvvvv]..... - Set Value to Analog Output (x=0-7/A output, vvvvv=0.0-10.0U)
SA20..... - Set Value 0 to all Analog Outputs
SA2SP..... - Set Analog Startup Values to all Analog Outputs
SP..... - Read Startup Outputs
SPD -$[xxxxxxxx]..... - Set Startup Outputs [0..7] (x=0/1 off/on status)
SPAx [vvvvv]..... - Set Analog Startup Output (x=0-7/A output, vvvvv=0.0-10.0U)
TM..... - Read Timeout Status (0..7 digital status - set time)
TM -[x]..... - Set Timeout Time (x=0-8)
TM -$[xxxxxxxx]..... - Set Timeout Outputs [0..7] (x=0/1 off/on status)
PLCy..... - Read PLC (Mask - Filter) (y=0-7 digital output)
PLCy -M[xxxxxxxx]..... - Set PLC Mask (y=0-7 output, x=0/1 off/on I0..I7)
PLCy -F[xxxxxxxx]..... - Set PLC Filter (y=0-7 output, x=0/1 off/on I0..I7)
FR..... - Read the Fast Response Mode Status
FRx..... - Fast Response Mode (x=0/1 off/on status)
CP..... - Change telnet password
Q..... - Quit
?..... - Help
  
```

Picture 18: *telnet* server access page and help request.

This service allows to read analogical and digital I/O status, to read card parameters and to control outputs. All commands are case-insensitive.

Commands list:

Command	Description	Answer type
Q	Closes telnet connection	
SN	Requests board serial number	1
FV	Requests firmware version	1
BD	Requests firmware build date	1
SV	Requests TCP/IP stack version	1
HN	Requests board hostname	1
MAC	Requests board MAC address	1
IP	Requests board IP address	1
SUB	Requests board Subnet mask	1
GW	Requests board Gateway address	1
DNS	Requests board Primary DNS server address	1
DNS2	Requests board Secondary DNS server address	1
WS	Requests current SSID for the WiFi connection	1
WA	Requests current Authentication type for the WiFi connection	1
WK	Requests current Key for the WiFi connection	1
Dlx	Requests digital input status (x = 0-7 / A → all)	2
DOx	Requests digital output status (x = 0-7 / A → all)	2
Alx	Requests analogical input status (x = 0-7 / A → all)	2, 3
AOx	Requests analogical output status (x = 0-7 / A → all)	2, 3
ADx	Activates related digital output (x = 0-7 / A → all)	4
SDx	Disables related digital output (x = 0-7 / A → all)	4
AAx [vvvvv]	Sets analogical output x (x = 0-7 / A → all) with a value vvvvv included in the 0.00V-10.00V range	4
SA20	Sets all analogical output with a 0.00V value	4
SA2SP	Sets all analogical output with their startup value	4
SP	Requests all startup outputs status	2, 3
SPD -S[xxxxxxxx]	Sets startup status (x = 0/1 – Off/On) of each digital output, from Out0 to Out7	4
SPAx [vvvvv]	Sets startup status of analogical output x (x = 0-7 / A → all) with a value vvvvv (0.00V-10.00V range)	4
TM	Requests timeout settings (digital outputs status Out0..Out7 – timeout time [0-8])	1
TM -T[x]	Sets timeout time (x = 0-8)	4
TM -S[xxxxxxxx]	Sets timeout status (x = 0/1 – Off/On) of each digital output, from Out0 to Out7	4
PLCy	Requests mask and filter settings (M0..M7 – F0..F7 related to In0..In7 digital inputs) for the y digital output (y = 0-7)	1
PLCy -M[xxxxxxxx]	Sets the mask status (x = 0/1 – Off/On) of each digital input, from In0 to In7, for the y digital output (y = 0-7)	4
PLCy -F[xxxxxxxx]	Sets the filter status (x = 0/1 – Off/On) of each digital input, from In0 to In7, for the y digital output (y = 0-7)	4
FR	Requests Fast Response status (0/1 = Off/On)	5
FRx	Set Fast Response status (x=0/1 – Off/On)	4
CP	Enables telnet service password	
?	Command help	

The typing of an excessive number of chars (over 29) saturates the receiving buffer of the card and consequently the session will be lost.

The following table lists the kind of answer related to the edited command:

Answer type	Description
1	The answer, by default, is preceded by a 18 chars length descriptive string. For example the SN command generates the following answer: "Serial number: 2010000". If FR option is on, the introductive string is omitted: "2010000".
2	The answer, by default, is preceded by a descriptive string with variable length, related to the typed command. If the FR option is on, the introductive string is omitted.
3	The answer is divided in several row.
4	The answer to these I/O setting commands is: "\x1b[34mdone \x1b[0;1m".
5	The answer is made by a single char: 0 = Off, 1 = On.

The next table encode the timeout time parameter used in TM and TM -T[x] commands:

Parameter	Value
0	No timeout
1	5 seconds
2	10 seconds
3	30 seconds
4	1 minute
5	5 minutes
6	10 minutes
7	30 minutes
8	1 hour

## DEVELOPMENT OF CONTROL APPLICATIONS WITH *telnet* PROTOCOL

It is possible to develop a control application for the WEB-ADIO-WiFi board based on telnet Server: the user program should be able to manage the strings generated from the server.

The following are the strings used in the program, with a brief description of them.

Server telnet access string.

"\x1b[2J\x1b[31m\x1b[1mWEB-ADIO-WiFi Telnet Server 1.0\x1b[0m\r\nTo access the service insert the password \r\nPassword: "

Answer string to incorrect password: the telnet socket will be closed.

"\r\nAccess denied\r\n\r\n"

Answer string to correct password: the command prompt will be shown.

"\r\n\r\n\x1b[1;32mLogged in successfully\x1b[0m - Press 'q' to quit\r\n\r\n"

Command prompt: it is shown after each command executed, except CP command.

"\r\n> "



Answer string to each invalid command or request

```
"\x1b[33merror\x1b[0;1m"
```

## UTILITY DESCRIPTION

The FRx (Fast Response) command allows to enable or disable the printing of the descriptive strings. This utility is useful to write codes in which the program focus his resource only to process the data received in a synthetic form, without parsing all the strings.

The command is disabled by default at every server access.

The CP (Change Password) command is made by three phases: in the first it is requests to insert the new password:

```
"\r\nEnter new password: "
```

Next is request to confirm the new password:

```
"\r\nConfirm new password: "
```

Now, if the passwords match is valid, the answer string will be:

```
"\r\n\r\nPassword changed successfully!\r\n"
```

Otherwise it will be:

```
"\r\n\r\nPassword change fails!\r\n"
```

The change of the password in telnet does not perform a reboot of the board or the automatic disconnection from the current session, on the contrary to what happens in the analogous http service. Obviously, next telnet access to board, here included the use of demo software, must be authorized by the new password.



## SNMP SERVER

To connect the SNMP server implemented on the board it is possible to use any MIB browser program, like *iReasoning MIB Browser*<sup>2</sup>.

After starting the communication with the board it is necessary to be sure the browser is correctly configured, with the following check list.

- The MIB Tree must include the .mib file provided with the CD. To load it, use the command “File → Load MIBs” and search through the folders, selecting the file *webadiowifi.mib*.
- The Agent must be configured properly with communities parameters. To verify it, use the command “Tools → Options” and select the tab Agents. The *Add button* allows to configure a new Agent, setting IP board address, Port (161), Version (2), Read and Write Communities.

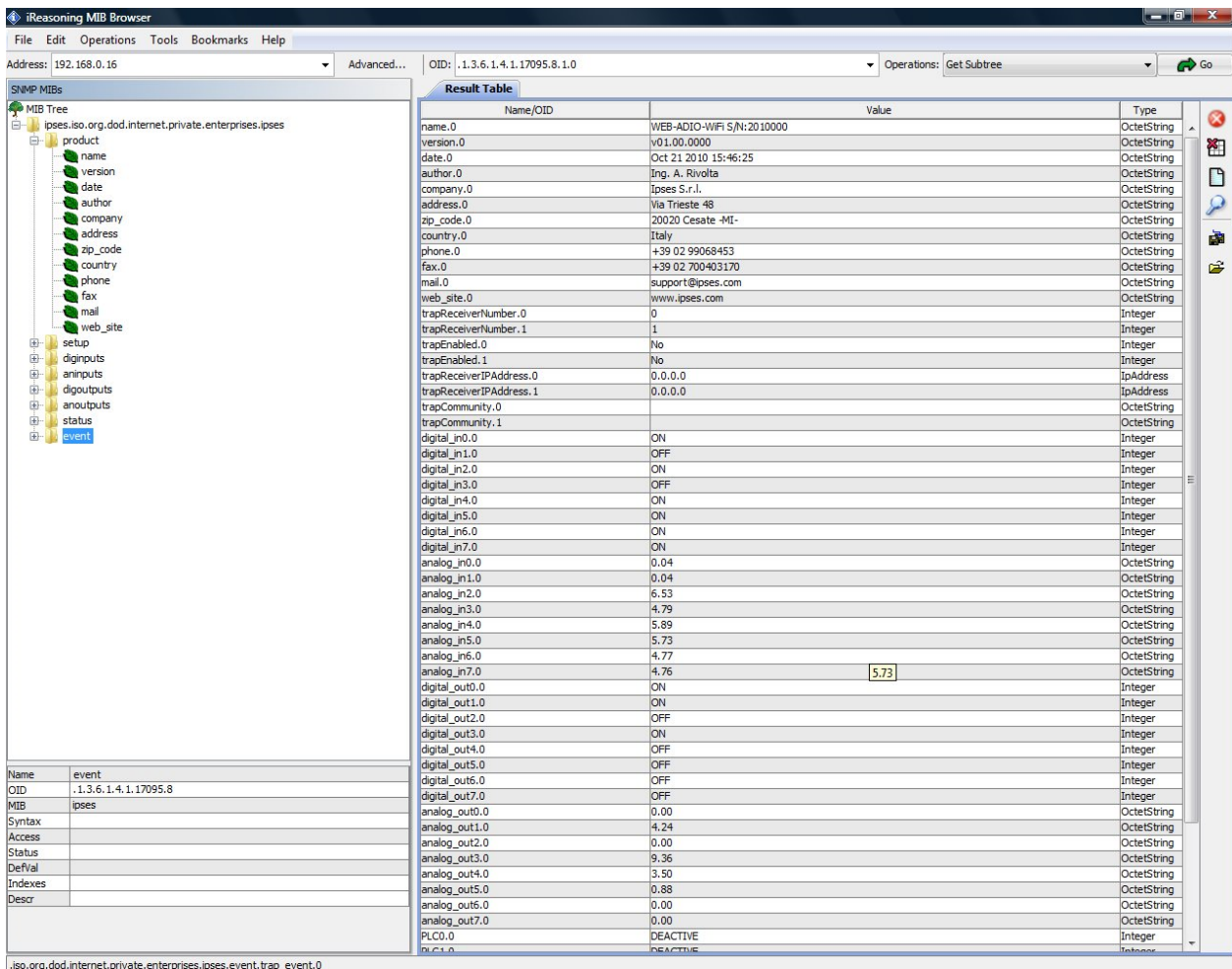

Name/OID	Value	Type
name.0	WEB-ADIO-WIFI S/N:2010000	OctetString
version.0	v01.00.0000	OctetString
date.0	Oct 21 2010 15:46:25	OctetString
author.0	Ing. A. Rivolta	OctetString
company.0	ipses S.r.l.	OctetString
address.0	Via Trieste 48	OctetString
zip_code.0	20020 Cesate -MI-	OctetString
country.0	Italy	OctetString
phone.0	+39 02 99068453	OctetString
fax.0	+39 02 700403170	OctetString
mail.0	support@ipses.com	OctetString
web_site.0	www.ipses.com	OctetString
trapReceiverNumber.0	0	Integer
trapReceiverNumber.1	1	Integer
trapEnabled.0	No	Integer
trapEnabled.1	No	Integer
trapReceiverIPAddress.0	0.0.0.0	IpAddress
trapReceiverIPAddress.1	0.0.0.0	IpAddress
trapCommunity.0		OctetString
trapCommunity.1		OctetString
digital_in0.0	ON	Integer
digital_in1.0	OFF	Integer
digital_in2.0	ON	Integer
digital_in3.0	OFF	Integer
digital_in4.0	ON	Integer
digital_in5.0	ON	Integer
digital_in6.0	ON	Integer
digital_in7.0	ON	Integer
analog_in0.0	0.04	OctetString
analog_in1.0	0.04	OctetString
analog_in2.0	6.53	OctetString
analog_in3.0	4.79	OctetString
analog_in4.0	5.89	OctetString
analog_in5.0	5.73	OctetString
analog_in6.0	4.77	OctetString
analog_in7.0	4.76	OctetString
digital_out0.0	ON	Integer
digital_out1.0	ON	Integer
digital_out2.0	OFF	Integer
digital_out3.0	ON	Integer
digital_out4.0	OFF	Integer
digital_out5.0	OFF	Integer
digital_out6.0	OFF	Integer
digital_out7.0	OFF	Integer
analog_out0.0	0.00	OctetString
analog_out1.0	4.24	OctetString
analog_out2.0	0.00	OctetString
analog_out3.0	9.36	OctetString
analog_out4.0	3.50	OctetString
analog_out5.0	0.88	OctetString
analog_out6.0	0.00	OctetString
analog_out7.0	0.00	OctetString
PLC0.0	DEACTIVE	Integer
PLC1.0	DEACTIVE	Integer

<sup>2</sup> Downloadable from [www.ireasoning.com](http://www.ireasoning.com) web site

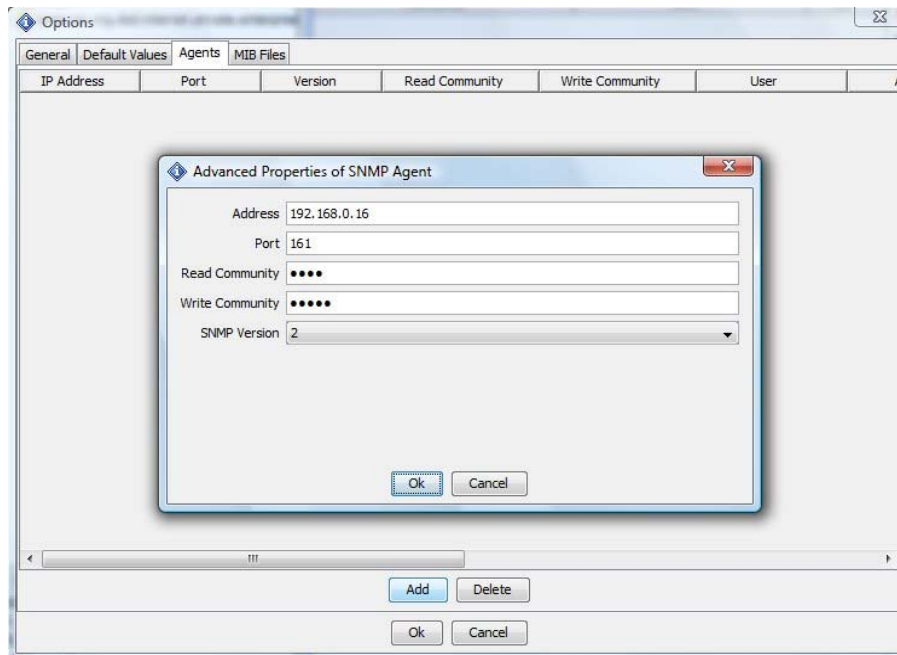

Picture 19: MIB browser and SNMP Agent configuration.

Picture 19 shows the MIB browser and the configuration of the SNMP Agent parameters. The MIB Tree has eight branches, each of them has several leafs:

- *product*, where to read information about the board
- *setup*, where to set the parameters for two different traps
- *diginputs*, where to read digital input status
- *aninputs*, where to read analogical input values
- *digoutputs*, where to read or set the digital output status
- *anoutputs*, where to read or set the analogical output value
- *status*, where to read the PLC and Timeout function status (On/Off)
- *events*, which is the container of the variable associated to the Trap's event.

Using SNMP server is not possible to configure the PLC and Timeout functions.

The *Operations* selector specifies the request to be sent to the server. The answers to reading requests are shown in the Result Table; instead, to set a parameter, is mandatory to insert the value, according to the kind specified, in the relevant form of the pop-up window.

For further information about commands and functions, consult your browser helper.





## TRAP EVENTS

The SNMP server implemented on WEB-ADIO board can generate two separate Trap events, both of them associated to a change of digital inputs status. Each event can be configured independently.

The Traps generated are compliant to v2c protocol specification and the information is stored in a sequence of two varbinds as 8 bit format: the first one encoding the digital input status (In0 – In7), the second one encoding the digital output status (Out0 – Out7).

The parameters to configure, for each event, are:

- trapEnable: 0/1 respectively to disable/enable the event notify.
- trapReceiverIPAdress: IP address of the receiver machine (i.e. the IP address of your PC).
- trapCommunity: a valid community name to receive the event notify.

By default, the parameters of the Trap events are reset at every rebooting: to avoid this condition set the *save\_option* variable in the *setup* path before to configure the parameters values. If the *save\_option* variable is deactivated at the startup, the parameters are resetted.

To see in your mib browser the list of the events generated, is necessary to open the *Trap Receiver* window with the “Tools → Trap Receiver” command.



## PROBLEMS RESOLUTION:

The next section lists some procedure steps to investigate board malfunctions. If the problem will be not solved, contact the technical support of IPSES S.r.l. sending the Engineering Problem Report included in this manual or downloadable from IPSES website at the following address [http://www.ipses.com/PDF/IPSES-engineering\\_problem\\_report.pdf](http://www.ipses.com/PDF/IPSES-engineering_problem_report.pdf)

- Verify the correct power supply and operation of the board (see status LEDs).
- Verify the correct connection of the network cable both on board and LAN side (network card, switch ...) and if the board is visible from the network (if cabled interface is active).
- Verify the compatibility of board addresses (IP, subnet, gateway) in the operative network. If there is no compatibility, ensure to configure them properly.
- Verify the SSID, Authentication and Key parameters are correctly configured to connect to the AP (if wireless interface is active).
- Try to ping the IP address of the board.
- Make sure the IP address in the URL field is correct (*http* service).
- Verify there are no more than 5 simultaneous connection opened on the same board (*http* service).
- Make sure the password inserted in the TCP/IP Configuration page is correct (*http* service).
- Make sure the *telnet* communication port is number 23 (*telnet* service).
- Make sure the *telnet* access password is correct: it is case sensitive (*telnet* service).
- Verify there is no telnet communication already active on the board, via telnet client or demo software (*telnet* service).
- Verify the DNS server addresses correctness for the ping query.
- Verify the address entered with the ping function (*http* service).
- Check the MIB browser is set properly through the .mib correct file loading and communities settings (SNMP service).

## DEMO SOFTWARE

A CD with a demo software is provided with the card. This demo software for Windows O.S., based on *telnet* service, allows to manage the main functions of WEB-ADIO-WiFi. To use this software, it is necessary a telnet communication is not already opened on the card, while a *http* communication service can exist simultaneously with. This software allows to manage up to 100 WEB-ADIO-WiFi devices simultaneously connected to the network.

At the software start-up, the program shows a windows (Picture 20) where it is possible to initialize the devices connection to be managed through the software. To open the connection with a card, insert its *IP address* and its *telnet Password* in the relevant fields, then click on the *Connect* button. After few seconds, if the connection will be successfully opened, the *IP address*, *password* and *serial number* parameters of the board will be shown on *Connected devices* table; otherwise an error message will be shown in the *Operation message* indicator. The *Start Program* button will be enabled only when the connected device list will contain almost one connected device. It is no possible to add other devices once the initialization phase is terminated: to do this, close the program and restart it repeating the initialization steps. The *Quit Program* button allows to close the software without opening the main window.

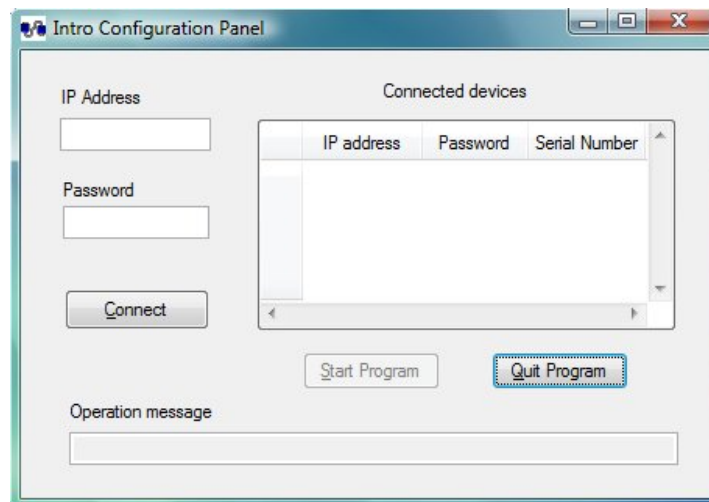

Picture 20: Initialization connection panel of the demo software.

In Picture 21a there is a snapshot of the main window of the software. To enable the control of one of the initialized cards it necessary to select its *Serial Number* from the *Device S/N* ring menu. The selection of a new board allows to automatically update the inputs and outputs status and to update *Firmware Version* and *IP Address* fields.

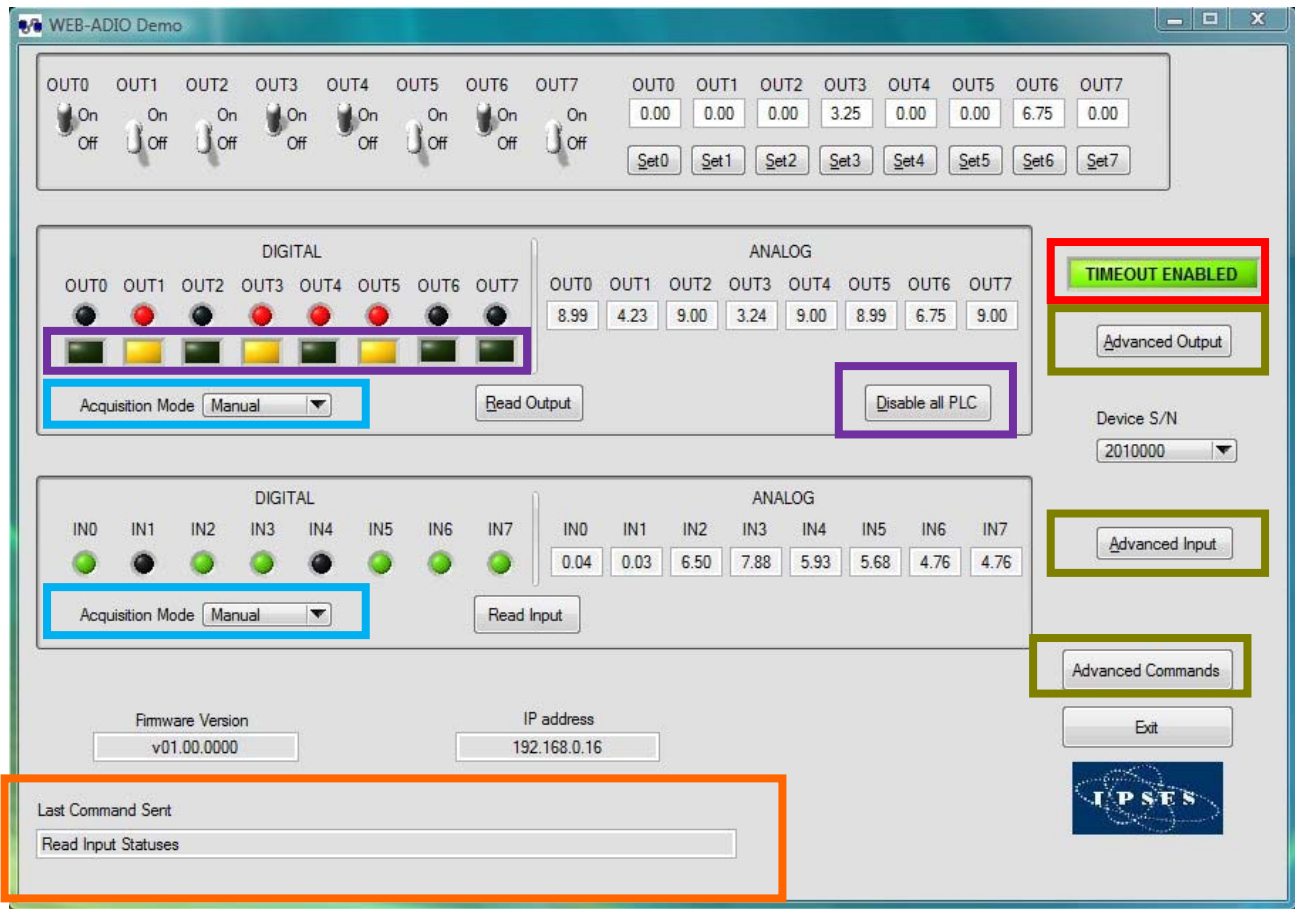

Picture 21a: Main windows of the demo software.

The field *Last Command Sent* (surrounded in orange in Picture 21a) shows the last executed operation.

In the upper section of the window there are the selectors and the controls to drive directly in real time the digital and analogical outputs.

while the *Read Output* button update the software output LEDs exactly as in the card (the software colour, red, is the same of the card).

Both logic inputs and outputs status can be achieved by two ways, thanks to the selectors ring menu (surrounded in blue in Picture 21a): the manual mode performs an asynchronous acquisition when you push respectively the *Read Input* button or *Read Output* button, while the automatic mode performs a continuous polling of the inputs and/or outputs state. The polling rate are customizable by the *Polling Time* controls (showed in Picture 21b): these fields accept values between 1.5s and 10s, with a step of 0.5s. In both cases, the relevant virtual indicators are updated at every acquisition: the software LEDs, with red colour for outputs and green colour for inputs, are associated to digital channels, while text indicators are associated to analogical channels.

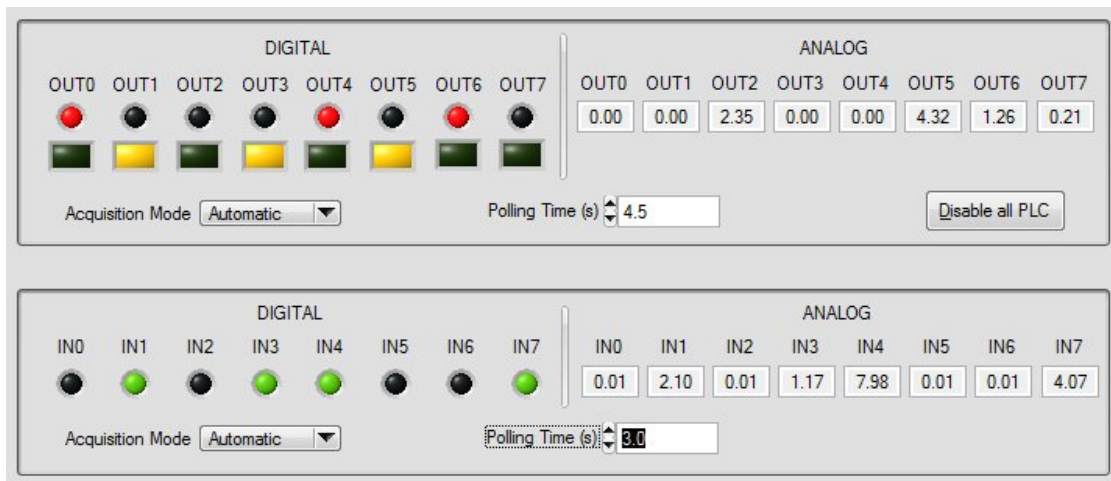

Picture 21b: Automatic acquisition mode of the inputs and the outputs.

The objects in the purple section (see Picture 21a) allow to configure the masks and filters for PLC functions. Clicking on square LED referred to an output will appear a pop-up window, as shown in Picture 22. For each output the square LED is on only when almost an input is masked, so the PLC function is enabled, otherwise it is off and the PLC function is disabled. The *Disable all PLC* button resets and stores all masks for each output, without modifying any filter.

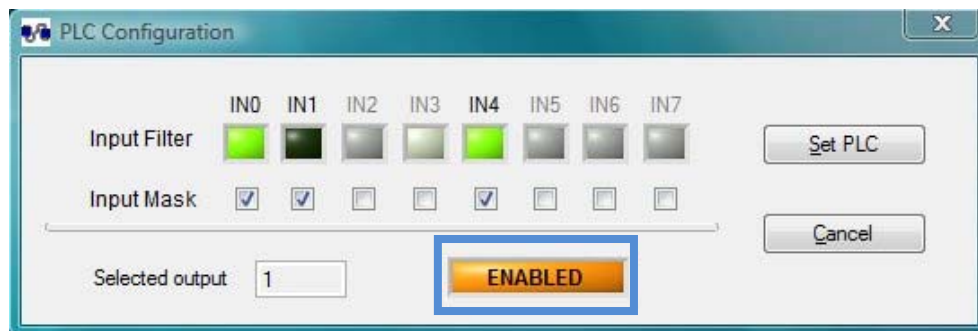

Picture 22: mask and filter PLC configuration pop-up window.

At the pop-up window loading, the mask and filter configuration currently stored for the selected output is shown. If a mask of an input is enabled, it is possible to modify its filter status too, otherwise the last one is dimmed. To modify a filter status, click on the relative square LED. If all inputs are not masked, the notify square LED, surrounded in blue in Picture 22, is off and the "DISABLED" message appears. The *Set PLC* button allows to store the configuration settings, while the *Cancel* button close the pop-up window without saving them. The square LED surrounded in red in Picture 21a shows the status of the Timeout function. If it is disabled, the LED is off and appear the TIMEOUT DISABLED message.

Three buttons on the right (surrounded in green in Picture 21a) allow to open three windows: one for the outputs (*Advanced Output*), one for the inputs (*Advanced Input*) and the last one for the read and write commands in the non volatile memory (*Advanced Commands*).



The *Advanced Output* window (see Picture 23) allows the typical operations you can perform on the outputs of the device.

The output commands are listed below:

- Activation/Deactivation of each output for the digital channel
- Settings of the voltage level of each outputs for the analogical channel
- Reading of the status of each output for digital channel
- Reading of the set value of each output for analogical channel
- Setting and reading of a single output for both channels
- Reset of the digital outputs (all outputs are switched off)
- Reset of the analogical outputs (they can be set to 0V or assume the start-up configuration)
- Reading of the start-up configuration for both channels
- Setting of the start-up configuration for digital and/or analogical channel
- Reading of the Timeout function configuration (digital outputs status and timeout time)
- Settings of the Timeout function configuration (digital outputs status and timeout time)



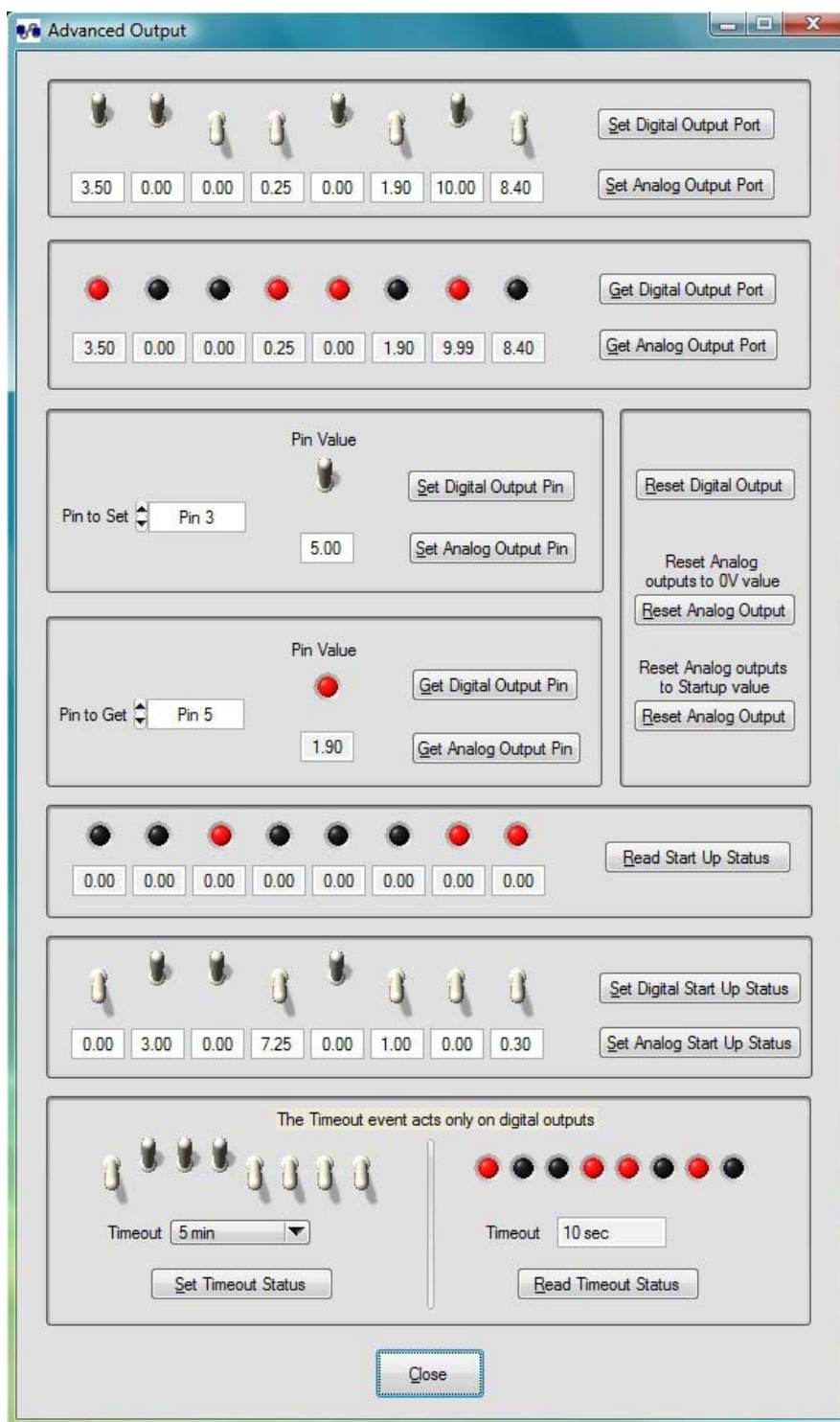

Picture 23: Advanced Output window.



*Advanced Input* window (see Picture 24) allows the typical operations you can performed on the inputs of the device. The input commands are listed below:

- Reading of the status/value of each input for the digital/analogical channel
- Reading of the status/value of a single input for the digital/analogical channel

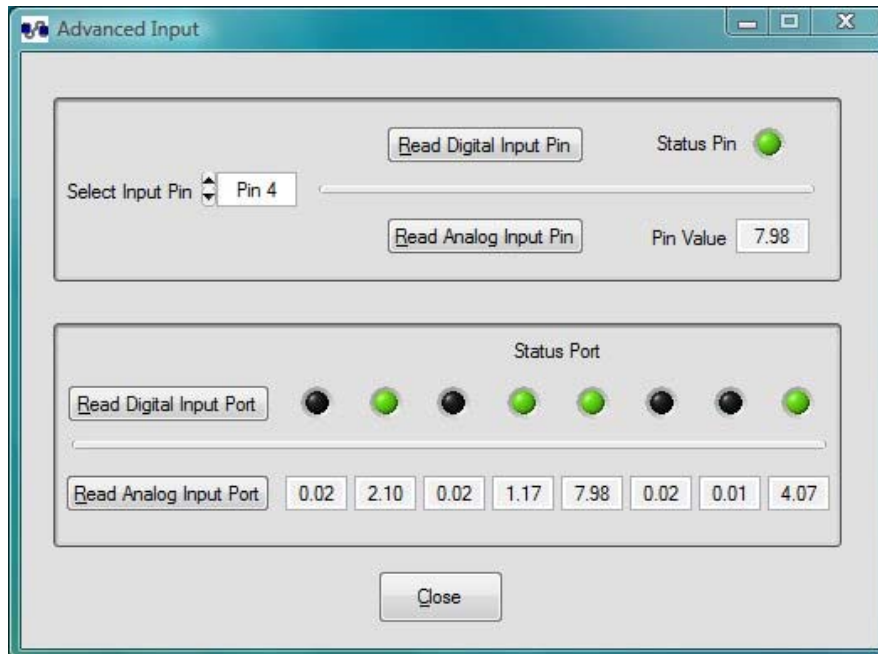

Picture 24: Advanced Input window.

The *Advanced Commands* window (see Picture 25) displays all TCP/IP, wireless configuration and firmware parameters of the current board and allows to change the *telnet* password.

The new *telnet* password must be inserted in the *New Password* field and replied in *Confirm New Password* field: it could be any alphanumeric strings with a valid length which is included between one and eight characters.

The *Enable Change Password* checkbox enables the *Set New Password* button. The result of the modifying command will be shown in the *Last Command Sent* field in the lower part of the main panel, while if an error is generated by the password validity check operation, the error message will be popped up.





**Advanced Commands**

Serial Number: 2010000

**TCP/IP Board Parameters**

MAC Address: 00:04:A3:00:00:01

Hostname: WEBADIOWIFI

IP Address: 192.168.0.16

Subnet Address: 255.255.255.0

Gateway Address: 192.168.0.4

DNS Address: 193.70.152.15

DNS2 Address: 0.0.0.0

**General Board Parameters**

Firmware version: v01.00.0000

Stack Version: v5.25

Build Date: Oct 21 2010 15:46:24

Enable change password

New Password: password

Confirm New Password: password

**WiFi AP Parameters**

SSID: WEB-AP

Encryption: WEP 104 bit

Key: www.ipses.com

Picture 25: Advanced Command window.



## TCP/IP ADDRESS CONFIGURATOR SOFTWARE



WEB-ADIO-WiFi Address Configurator, provided with the card, is a software which allows to configure remotely TCP/IP addresses and wireless parameters for WEB-ADIO-WiFi control units. The configuration of the device is achieved through both Ethernet interface, than wireless interface. In the last case it is necessary that the card can connects itself to the Access Point, i.e. the SSID and authentication parameters must be correct.

To work properly, only one card per time must be set in address configuration mode, even if you have more than one WEB-ADIO-WiFi board connected.

WEB-ADIO-WiFi Address Configurator software is able to communicate with every IP address, excluded the reserved broadcast address (255.255.255.255). That means it is possible to configure also cards with out-of-net IP addresses.

## ADDRESS CONFIGURATION MODE

To enable the hardware *address configuration* mode, follow the procedure listed below:

- with the WEB-ADIO-WiFi board already powered on, insert jumper J2 (see picture below).
- perform the desired software configuration.
- at the end of the configuration, remove jumper J2.

Do not disconnect the power supply during the address configuration procedure. A supply reset, with the jumper J2 inserted, will restore the factory parameters.

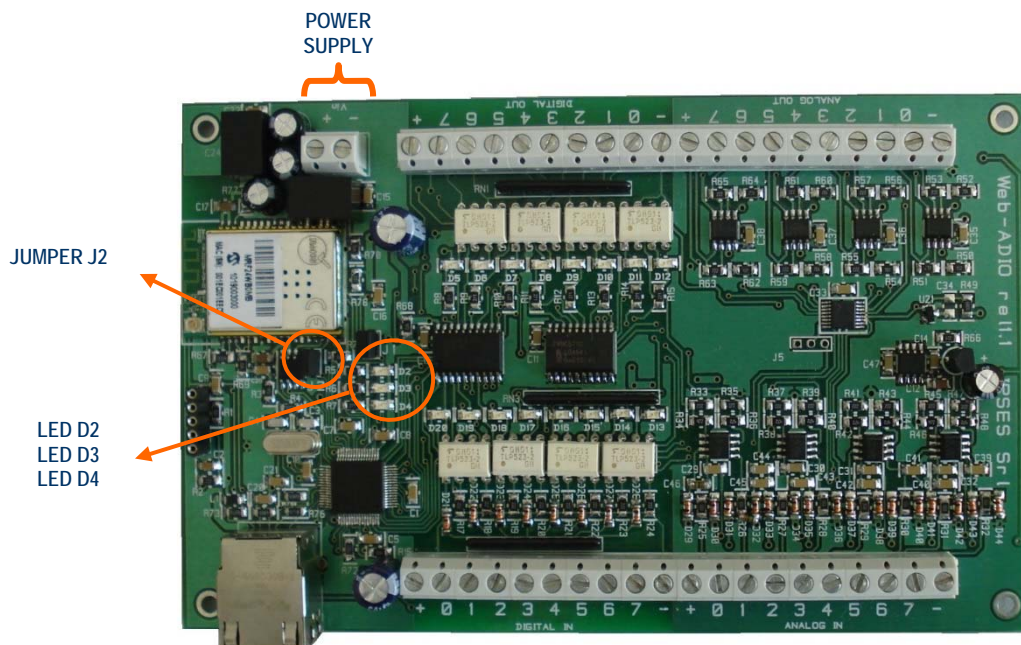

Picture 26: WEB-ADIO-WiFi card

## ADDRESS CONFIGURATOR CONTROL PANEL

The *WEB-ADIO-WiFi Address Configurator* control panel, shown in Picture 27, allows to configure both TCP/IP parameters, like IP address, Subnet mask address, Gateway address and Primary and Secondary DNS server addresses, than wireless parameters to connect to the Access Point. The modification of these last ones can be enabled by the user. Every field is saved on the board: it is important to compile each field with correct values.

The *Reboot enable* checkbox allows to perform a software rebooting of the card after the address configuration is successfully ended.

If the configuration process ends successfully, the status LEDs D2 and D3 on the board will flash for about one second.

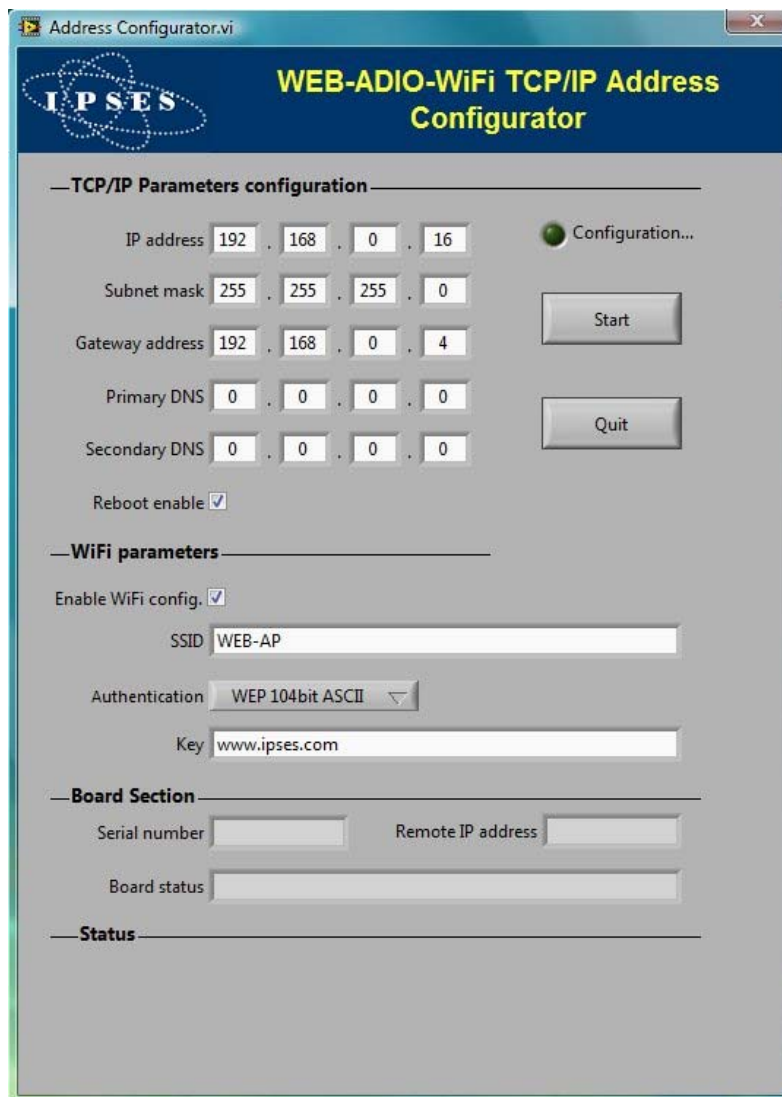

Picture 27: WEB-ADIO-WiFi Address Configurator software control panel

To send the new TCP/IP address and WiFi parameters configuration, click the *Start* button; during the communication with the card the *Configuration* LED is on.

To exit the software, click on *Quit* button.



If the communication handshake to the card has success, the *Serial number* and *Remote IP address* fields in the *Board Section* are filled respectively with the current S/N and IP address of the card, as shown in Picture 28. The Board status field shows a message about the progress of the configuration status.

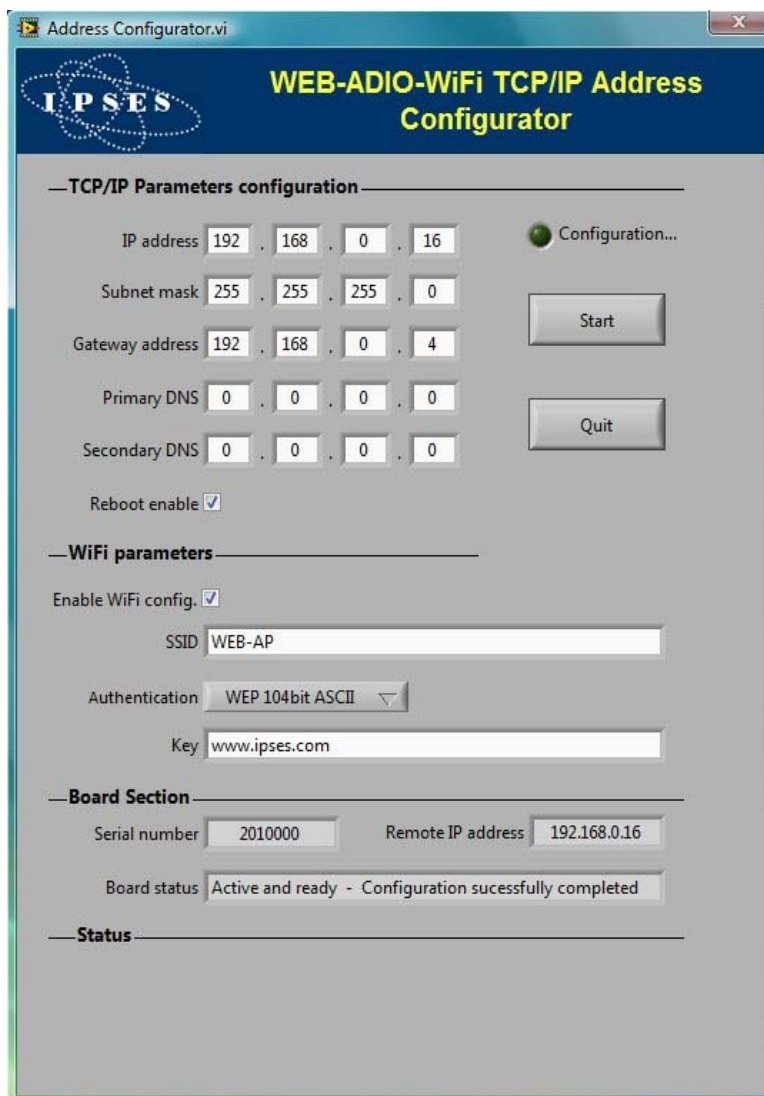

Picture 28: Configuration successfully completed.

If a communication error occurs, the *Serial number* field is empty and the *Remote IP address* field shows an invalid IP address (0.0.0.0), while an error message is shown in the *Status* section and the *Start* and *Quit* buttons are disabled until the error is reset, as shown in Picture 29.



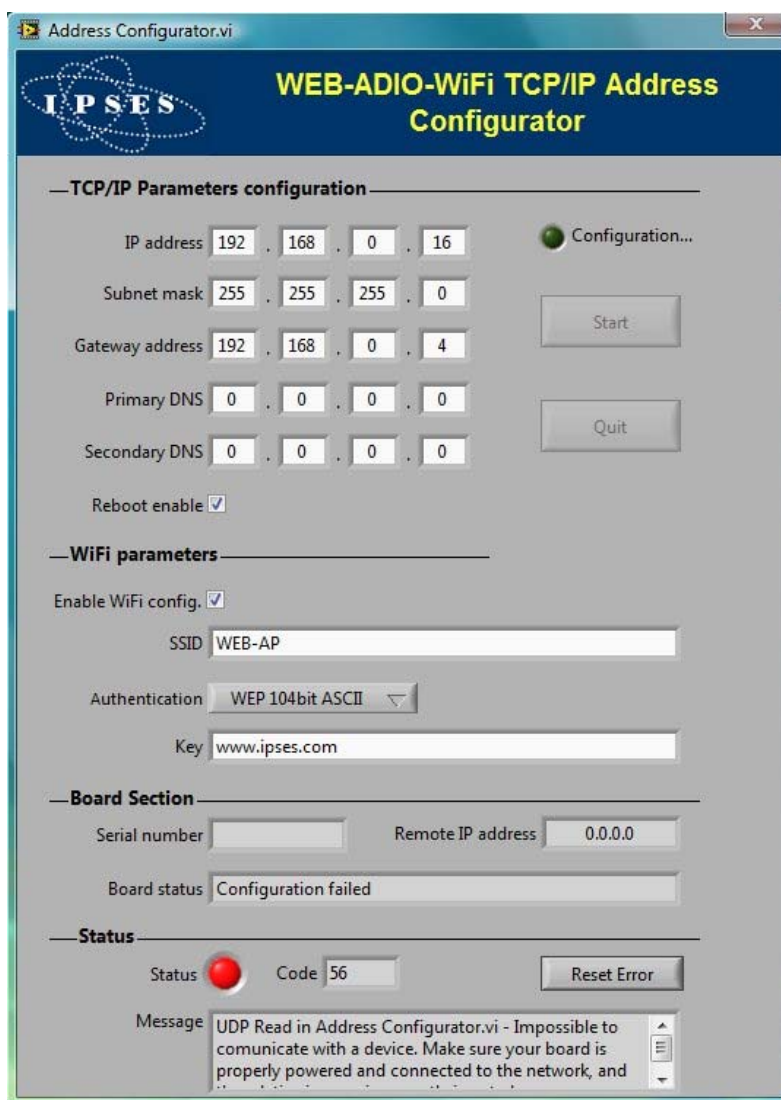

Picture 29: Error during configuration.

To configure another card, perform the necessary hardware set on the board, then type new addresses and click on the *Start* button.

Note: if you use Windows Vista or Windows 7 on your PC, your operative system could ask you to unlock a firewall restriction when you click on the *Start* button. Confirm the unlocking of the firewall restriction, otherwise the communication of the software via Ethernet will be interdicted from the operative system.



## PRODUCT CODE

Code	Description
WEB-ADIO-WiFi	Industrial control board with Ethernet and WiFi interfaces, with 8 digital inputs, 8 analogical inputs, 8 digital outputs and 8 analogical outputs. Web, telnet and SNMP servers integrated. WiFi antenna integrated.
WEB-ADIO-WiFi-U.FL	Industrial control board with Ethernet and WiFi interfaces, with 8 digital inputs, 8 analogical inputs, 8 digital outputs and 8 analogical outputs. Web, telnet and SNMP servers integrated. Ultra miniature coaxial (U.FL) connector for external antenna connection.
WEB-IOLibrary	LabView library (version 8.6 or later) for WEB-IO and WEB-ADIO cards (all models).
Euro-DIN	DIN universal rail for I/O cards (Eurocard format).
ETH-CABLE	Ethernet cable for WEB cards (length: 2,00 m)

## TECHNICAL FEATURES

Power supply: external, from 15V to 32V (continuous current)

Maximum current consumption: 70mA @15Vdc

Working temperature: from 0°C up to +60°C

Storage temperature: from -40°C up to +85°C

Ethernet interface: 1 Ethernet RJ45 port

### Wireless interface:

Standard WiFi 802.11b (2,4GHz)

Authentication supported: WEP, WPA(Personal) e WPA2(Personal)

Transmit power: 10dBm (10mW)

Receiver sensitivity: -83dBm

Built-in antenna or *ultra miniature coaxial* (U.FL) connector for external antenna connection

Configurable to connect to any *Access Point*, with any channel and SSID.

Card dimensions: 160 x 100 x 20 mm (6.30 x 3.94 x 0.79 inches)

### Inputs:

Digital interface: eight optocoupled inputs

Maximum applicable voltage:

36V

Input Impedance:

≈ 2.5Kohm

Logical LOW level:

< 1V

Logical HIGH level:

> 2.5V

Maximum absorbed current:

10mA

Analogical interface: eight calibrated inputs in common mode configuration

Maximum applicable voltage:

10V



Input impedance: > 1Mohm  
Maximum absorbed current: < 0.1mA  
Resolution of sampling (ADC): 10bit  
The “+” and “-” terminals referred to analogical channel have a stabilized 10V voltage across their heads, useful to power the analogical transducers. The maximum current driven from +10V connectors, both input than output, is 450mA.

#### Outputs:

Digital interface: eight optocoupled outputs in an open-collector configuration  
Maximum output voltage: 36V  
Maximum output current: 150mA  
Response average time: 100µs

Analogical interface: eight calibrated voltage outputs, with low impedance driver  
Maximum output voltage: 10V  
Maximum output current: ± 25mA  
Response average time: 6ms  
DAC resolution: 10bit

The “+” and “-” terminals referred to analogical channel have a 10V voltage across their heads, useful to power the analogical actuators. The maximum current driven from +10V connectors, both input than output, is 450mA.

#### Protection:

For the digital interfaces there are optocouplers with 2.500V<sub>RMS</sub> maximum operative isolation voltage.  
For the analogical input interface there is an overvoltage protection on every inputs.

#### Connectors:

Pitch terminal block for all the I/O and power supply connectors.

#### Supported protocols:

Telnet: the card can work as a telnet server  
HTTP: the card can work as a web server  
SNMP: the card can work as an SNMP server



## IPSES I/O CARD AVAILABLE MODELS

### IO-69: Input/output Card with 6 inputs and 9 relay outputs and USB interface



IO-69-USB is a self-powered card to manage six optocoupled inputs and nine relay outputs with USB interface.

A timeout control allows to protect the connecting devices, turning off all the outputs if it does not receive commands from the host within a time configurable through software.

Furthermore, there is the possibility to program all the outputs so that each one will activate only when inputs reach assigned conditions: in this case, IO-69 acts like a programmable logic controller (PLC).

The card is produced in two versions: with single pole double throw relay (SPDT) and with single pole single throw relay (SPST).

### IO-1616: Input/output Card with 16 inputs and 16 outputs and USB or RS232 interface

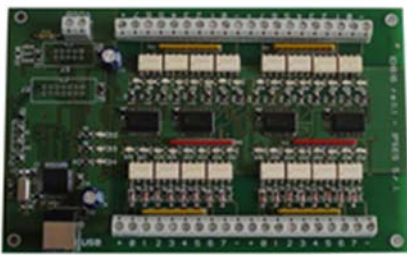

IO1616 is a self-powered card to manage sixteen optoisolated inputs and sixteen optoisolated outputs with USB interface. The model is available also with RS232 interface, in this case the card needs external power supply.

IO1616 can be directly connected to PLC, to input devices from operator and to other I/O systems. the status of each input

On request, an integrated temperature sensor allows to know in real time the temperature of the system IO1616 is placed in.

### CAN-I/O: Input/output Card with 16 inputs and 16 outputs with CAN, USB and RS232 interface



CAN-I/O is a control unit equipped with CAN, USB and RS232 interfaces to manage sixteen optocoupled inputs and outputs. The card can work as standalone device on CAN BUS. Its configuration is achieved either through USB (in this case the board is self-powered) or through RS232 interface. Easy to use and to configure, thanks to the provided software, CAN-I/O is the right answer to the need to acquire and to drive digital signals through already existing CAN bus.

CAN-I/O can be directly connected to PLC, to input devices by operator and to other I/O systems.

Each input and output status can be read by a field bus at any moment. Besides, thanks to LEDs fixed on, the status is shown directly on the board. An integrated temperature sensor allows to know in real time the temperature of the system CAN-I/O is placed in.





## WEB-IO: Input/output Card with 16 inputs and 16 outputs, Ethernet interface, integrated web, telnet and SNMP servers and SMTP client.



WEB-IO is a card to manage sixteen optocoupled inputs and sixteen optocoupled outputs with Ethernet interface, equipped with a web, a telnet and an SNMP servers, and an SMTP client. The web server allows to connect and to manage the card using any web browser (i. e. Internet Explorer or Firefox), with no needs to install a software on your PC. Besides, the card can be connected directly to a switch or to a router with no need to use a PC. It is also possible to develop a customized software managed by telnet service or SNMP client. The SMTP client allows to send alert email based on inputs status change events.

WEB-IO can be directly connected to PLC, to input devices from operator and to other I/O systems. Each input and output status can be read by a web browser or a telnet client at any moment, besides it is shown directly on the board thanks to LEDs fixed on. On request, the card can be equipped with an integrated temperature sensor which allows to monitor in real time the temperature around the regulator voltage module. Through expansion connectors the card can be interfaced to a RTCLOG (Real Time Clock and Logger) optional module: by this way, it can perform a log of the I/O states on a dedicated memory.

WEB-IO is available also in box version, it is provided with a demo software for Windows environment, based on telnet service.

## WEB-IO-WiFi: Input/output Card with 16 inputs and 16 outputs, Ethernet and WiFi interfaces, integrated web, telnet and SNMP servers



WEB-IO-WiFi is a card to manage sixteen optocoupled inputs and sixteen optocoupled outputs with Ethernet and WiFi interfaces, equipped with a web, a telnet and an SNMP servers. The web server allows to connect and to manage the card using any web browser (i. e. Internet Explorer or Firefox), with no needs to install a software on your PC. Besides, the card can be connected directly to a switch or to a router, by this way it can be accessed by any PC connected to Internet. It is also possible to develop a customized software managed by telnet service or SNMP protocol. The board is available with built-in antenna or with ultra-miniature coaxial (U.FL) connector for external antenna connection.

WEB-IO-WiFi can be directly connected to PLC, to input devices from operator and to other I/O systems. Each input and output status can be read by a web browser or a telnet client at any moment, besides it is shown directly on the board thanks to LEDs fixed on. On request, the card can be equipped with an integrated temperature sensor which allows to monitor in real time the temperature around the regulator voltage module.





## WEB-ADIO: Input/output Card with 8 analogical inputs, 8 digital inputs, 8 analogical outputs and 8 digital outputs, Ethernet interface, integrated web, telnet and SNMP servers



WEB-ADIO is a card to manage 8 optocoupled digital inputs, 8 analogical inputs, 8 optocoupled digital outputs and 8 analogical outputs with Ethernet interface, equipped with a web, a telnet and an SNMP servers. The WEB server allows to connect and to manage the card using any web browser (i. e. Internet Explorer and Firefox), with no needs to install a software on your PC Beside, the card can be connected directly to a switch or to a router with no need to use a PC.

It is also possible to develop a customized software managed by telnet service.

WEB-ADIO can be directly connected to PLC or to analogical transducer, to input devices from operator and to other I/O systems. The analogical inputs and outputs have an operative voltage from 0V to 10V, with a resolution of 10mV and are calibrated one by one. Each input and output status can be read by a web browser or a telnet client at any moment, besides, the status of digital inputs and outputs it is shown directly on the board thanks to LEDs fixed on.

## WEB-ADIO-WiFi: Input/output Card with 8 analogical inputs, 8 digital inputs, 8 analogical outputs and 8 digital outputs, Ethernet and WiFi interfaces, integrated web, telnet and SNMP servers



WEB-ADIO-WiFi is a card to manage 8 optocoupled digital inputs, 8 analogical inputs, 8 optocoupled digital outputs and 8 analogical outputs with Ethernet and WiFi interfaces, equipped with a web, a telnet and an SNMP servers. The web server allows to connect and to manage the card using any web browser (i. e. Internet Explorer and Firefox), with no needs to install a software on your PC Beside, the card can be connected directly to a switch or to a router with no need to use a PC. The board is available with built-in antenna or with ultra-miniature coaxial (U.FL) connector for external antenna connection.

It is also possible to develop a customized software managed by telnet service.

The analogical inputs and outputs have an operative voltage from 0V to 10V, with a resolution of 10mV and are calibrated one by one.

WEB-ADIO-WiFi can be directly connected to PLC or to analogical transducer, to input devices from operator and to other I/O systems. Each input and output status can be read by a WEB browser or a telnet client at any moment, besides, the status of digital inputs and outputs it is shown directly on the board thanks to LEDs fixed on.





## RELE' I/O: Interface module with 16 digital inputs that can control 16 SPDT relay outputs 5A

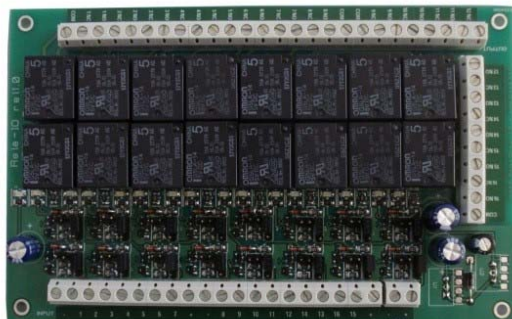

RELAY I/O(-SEL) is an expansion module with 16 digital inputs that can control 16 SPDT relay outputs 5A @ 250VAC or 5A @ 24VDC each

These modules can be used as an expansion for any I/O card, transforming the TTL or contact freedmen open-collector type outputs (up to a maximum of 16 ones) in 16 relay outputs with NO and/or NC contact.

IPSES provides two board models, based on different relay output tipology:

- RELÈ-IO board: the sixteen outputs are divided in two groups of eight with common COM contact and both NC and NO contacts available on output connectors.
- RELÈ-IO-SEL board: each output is independent and each relay provides COM contact and one contact selectable between NC and NO according dedicated selector configuration.

To operate the cards require an external power supply. Two version are available: RELÈ-IO(-SEL)-5 which requires an external power supply of 5V<sub>dc</sub> or RELÈ-IO(-SEL)-24 which requires an external power supply from 7V<sub>dc</sub> up to 24V<sub>dc</sub>.

The card is in standard Eurocad format (100 x 160 mm - 3,94 x 6,30 inches) and can be supplied mounted on opened DIN rail.

## N8-USB: Input Card with 8 inputs and USB interface



IN8 is a low size auto powered control unit equipped with USB interface. IN8 can check eight galvanic isolated inputs: on each input it is possible to apply voltages regardless from the USB ground, with a maximum voltage of 30V.

Easy to use, thanks to the driver provided with and to the LabVIEW library available on demand, IN8 also reduce installation costs.

The board low size to be easily integrated in several systems. Besides, IN8 has its inputs galvanically isolated to protect from electromagnetic disturbances and ground loops, improving its reliability and quality.

IN8 is the right answer to the need to acquire digital signals from a PC in an industrial environment.

## LabVIEW Library for I/O cards:



A complete library for LabVIEW, giving the feasibility of I/O devices remote control, is available on request. The Library allows to implement a LabVIEW application without knowing the details of the communication protocol, making the development quick and easy. Each library is provided with a help file which explains deeper each function included with.





## CONTACTS

IPSES S.r.l. conceives, projects and markets electronic and scientific instruments. The customized planning of our devices allows us to answer specific necessities for customers asking for embedded systems. IPSES clients enjoy access to a dedicated project engineering team, available as needed.

Our pool consists of highly competent professionals whose experience in this field is extremely strong. Thanks to constant updating and technical development, IPSES is a leading company, combining the dynamism of a young group into the competence and reliability of a qualified staff.

IPSES S.r.l.

Research and development office:  
Via Suor Lazzarotto, 10  
20020 Cesate (MI)  
Italy

tel. (+39) 02 39449519 - (+39) 02 320629547  
fax (+39) 02 700403170  
e-mail: [info@ipses.com](mailto:info@ipses.com)  
<http://www.ipses.com>





---

## SUPPORT INFORMATION

The customer is at liberty to contact the relevant engineer at IPSES S.r.l. directly.

Telephone	:	(+39) 02 39449519 (+39) 02 320629547
Fax	:	(+39) 02 700403170
Email	:	support@ipses.com

## PROBLEM REPORT

The next page is a standard template used for reporting system problems. It can be copied and send as a fax. Alternative bugs may be reported by emails, in this case please insure that the mail contains similar information listed in the *Engineering Problem Report* form.





## ENGINEERING PROBLEM REPORT

### Problem describer

Name		<b>IPSES s.r.l.</b> <b>Via Suor Lazzarotto, 10</b> <b>Cesate (MI)</b> <b>Italy</b> <b>Fax (+39) 02 700403170</b> <b>e-mail <i>support@ipses.com</i></b>
Company		
Date	Tel.	

### Product

Name	Version	Serial No.
------	---------	------------

### Report Type (bug, change request or technical problem)

Major bug	<input type="checkbox"/>	Urgency:	
Minor bug	<input type="checkbox"/>	High	<input type="checkbox"/>
Change request	<input type="checkbox"/>	Medium	<input type="checkbox"/>
Technical problem	<input type="checkbox"/>	Low	<input type="checkbox"/>

### Problem Description

### Reproduction of Problem

### IPSES s.r.l. Action notes

Received by	Date	Report No.	Action
-------------	------	------------	--------





(Product code WEB-ADIO-WiFi Rel. 01.00.0002)

**IPSES S.r.l.**  
Via Suor Lazzarotto, 10  
20020 Cesate (MI) - ITALY  
Tel. (+39) 02 39449519 – (+39) 02 320629547  
Fax (+39) 02 700403170  
e-mail: [info@ipses.com](mailto:info@ipses.com)  
[support@ipses.com](mailto:support@ipses.com)

